

MODEL TITANIUM
(Machine Code: C252)
SERVICE MANUAL

IMPORTANT SAFETY NOTICES

PREVENTION OF PHYSICAL INJURY

1. Before disassembling or assembling parts of the printer and peripherals, make sure that the power cord is unplugged.
2. The wall outlet should be near the printer and easily accessible.
3. If any adjustment or operation check has to be made with exterior covers off or open while the main switch is turned on, keep hands away from electrified or mechanically driven components.

HEALTH SAFETY CONDITIONS

1. If you get ink in your eyes by accident, try to remove it with eye drops or flush with water as first aid. If unsuccessful, get medical attention.
2. If you ingest ink by accident, induce vomiting by sticking a finger down your throat or by giving soapy or strong salty water to drink.

OBSERVANCE OF ELECTRICAL SAFETY STANDARDS

1. The printer and its peripherals must be installed and maintained by a customer service representative who has completed the training course on those models.

SAFETY AND ECOLOGICAL NOTES FOR DISPOSAL

1. Dispose of replaced parts in accordance with local regulations.
2. Used ink and masters should be disposed of in an environmentally safe manner and in accordance with local regulations.

Symbols

This manual uses several symbols. The meaning of those symbols are as follows:









	See or Refer to
	Core tech manual
	Clip ring
	E-ring
	Screw
	Connector

TABLE OF CONTENTS

1. INSTALLATION.....	1-1
1.1 INSTALLATION REQUIREMENTS.....	1-1
1.1.1 OPTIMUM ENVIRONMENTAL CONDITION	1-1
1.1.2 ENVIRONMENTS TO AVOID	1-1
1.1.3 POWER CONNECTION	1-1
1.1.4 MINIMUM SPACE REQUIREMENTS	1-2
1.1.5 DIMENSIONS	1-2
1.2 INSTALLATION PROCEDURE	1-3
1.2.1 MAIN BODY	1-3
1.2.2 ADDITIONAL DRUMS (OPTION)	1-12
1.2.3 INTERFACE BOARD (OPTION).....	1-13
2. PREVENTIVE MAINTENANCE	2-1
2.1 MAINTENANCE TABLE	2-1
3. REPLACEMENT AND ADJUSTMENT	3-1
3.1 GENERAL CAUTION.....	3-1
3.2 COVERS.....	3-1
3.2.1 PANEL / FRONT COVERS.....	3-1
3.2.2 REAR COVER	3-2
3.3 BOARDS.....	3-3
3.3.1 MPU.....	3-3
3.3.2 PSU	3-4
3.4 SCANNER	3-5
3.4.1 COVERS.....	3-5
3.4.2 1ST, 2ND FEED ROLLER / CIS (CONTACT IMAGE SENSOR)	3-6
3.4.3 DOCUMENT SENSOR	3-7
3.4.4 SCANNER MOTOR	3-7
3.5 MASTER FEED	3-8
3.5.1 MASTER MAKING UNIT.....	3-8
3.5.2 THERMAL HEAD	3-9
3.5.3 THERMAL HEAD VOLTAGE ADJUSTMENT	3-11
3.5.4 MASTER END SENSOR ADJUSTMENT	3-12
3.6 MASTER EJECT	3-13
3.6.1 MASTER EJECT UNIT	3-13
3.6.2 MASTER EJECT ROLLERS	3-13
3.7 PAPER FEED	3-14
3.7.1 PAPER FEED ROLLER / FRICTION PAD.....	3-14
3.7.2 PAPER FEED PRESSURE ADJUSTMENT.....	3-15
3.7.3 PAPER SEPARATION PRESSURE ADJUSTMENT	3-16
3.8 PRINTING.....	3-17
3.8.1 PRESS ROLLER	3-17
3.8.2 PAPER REGISTRATION ROLLER.....	3-18
3.8.3 PRESS ROLLER RELEASE LEVER ADJUSTMENT	3-20
3.8.4 PRINTING PRESSURE ADJUSTMENT	3-21

3.9 DRUM.....	3-22
3.9.1 PREPARATION	3-22
3.9.2 CLOTH SCREEN.....	3-22
3.9.3 CLAMPER / METAL SCREEN.....	3-24
3.9.4 INK PUMP ADJUSTMENT.....	3-26
3.9.5 DOCTOR ROLLER GAP ADJUSTMENT.....	3-28
3.9.6 INK DETECTION ADJUSTMENT	3-29
3.10 PAPER DELIVERY	3-30
3.10.1 PAPER DELIVERY UNIT.....	3-30
3.10.2 DELIVERY BELT / PAPER EXIT SENSOR.....	3-31
3.10.3 VACUUM FAN MOTOR POSITION.....	3-32
3.10.4 EXIT PAWL ADJUSTMENT.....	3-33
3.11 MAIN DRIVE.....	3-36
3.11.1 MAIN DRIVE TIMING BELT ADJUSTMENT.....	3-36
3.11.2 MAIM MOTOR PULLEY POSITION	3-37
3.12 FIRMWARE UPDATE.....	3-38
4. TROUBLESHOOTING.....	4-1
4.1 ERROR CODES.....	4-1
4.2 ELECTRICAL COMPONENT DEFECTS.....	4-2
4.3 FUSE, LED, VR, DIP-SW, AND TP TABLES.....	4-4
4.3.1 BLOWN FUSE CONDITIONS.....	4-4
4.3.2 LED'S.....	4-4
4.3.3 VR'S.....	4-4
4.3.4 TEST POINTS	4-5
4.3.5 DIP SWITCHES.....	4-5
4.4 JAM DETECTION.....	4-6
4.4.1 MASTER EJECT JAM (E JAM LOCATION INDICATOR).....	4-6
4.4.2 SCANNER JAM (P JAM LOCATION INDICATOR)	4-7
4.4.3 MASTER FEED JAM (D JAM LOCATION INDICATOR).....	4-8
4.4.4 DRUM JAM (B JAM LOCATION INDICATOR).....	4-9
4.4.5 PAPER FEED JAM (A JAM LOCATION INDICATOR +  + ) ...	4-10
4.4.6 PAPER DELIVERY JAM (C JAM LOCATION INDICATOR).....	4-11
5. SERVICE TABLES.....	5-1
5.1 SERVICE PROGRAM MODE.....	5-1
5.1.1 SERVICE PROGRAM MODE OPERATION.....	5-1
5.1.2 MAIN MENU NO.1: INPUT MODE.....	5-2
5.1.3 MAIN MENU NO.2: OUTPUT MODE.....	5-3
5.1.4 SP2-41: THERMAL HEAD SIGNAL OUTPUT (VHD SIGNAL).....	5-3
5.1.5 MAIN MENU NO.3: TEST MODE	5-4
5.1.6 SP3-1: FIRMWARE SUFFIX INFORMATION.....	5-4
5.1.7 MAIN MENU NO.6: ADJUSTMENT MODE	5-4
5.1.8 SP6-42: IMAGE ADJUSTMENT PATTERN PRINT	5-5
5.2 DIP SWITCHES.....	5-6
5.2.1 OVERVIEW.....	5-6
5.2.2 DIPSW101 NO.1 TO 4 – PAPER REGISTRATION POSITION ADJUSTMENT.....	5-7

5.2.3	DIPSW101 NO.5 TO 8 – MASTER WRITING POSITION ADJUSTMENT.....	5-8
5.2.4	DIPSW102 NO.1 TO 3 – THERMAL HEAD ENERGY CONTROL .	5-9
5.2.5	DIPSW103 NO.1 TO 4 – SCANNING SPEED ADJUSTMENT	5-10
5.2.6	DIPSW103 NO.5 TO 8 – MASTER FEEDING SPEED ADJUSTMENT.....	5-11

6.	DETAILD SECTION DESCRIPTIONS	6-1
6.1	MECHANISM OVERVIEW.....	6-1
6.1.1	MAJOR PARTS	6-1
6.1.2	ELECTRICAL COMPONENT LAYOUT	6-2
6.1.3	DRIVE LAYOUT.....	6-5
6.2	MASTER EJECT UNIT	6-6
6.2.1	OVERVIEW.....	6-6
6.2.2	MASTER CLAMPER OPENING MECHANISM	6-7
6.2.3	MASTER EJECT ROLLER MECHANISM.....	6-8
6.2.4	PRESSURE PLATE MECHANISM	6-9
6.3	SCANNER UNIT	6-10
6.3.1	SCANNER DRIVE	6-10
6.4	IMAGE PROCESSING	6-11
6.4.1	IMAGE PROCESSING FLOW	6-11
6.5	MASTER FEED	6-12
6.5.1	OVERVIEW.....	6-12
6.5.2	MASTER FEED MECHANISM.....	6-13
6.5.3	CLAMPER AND TENSION ROLLER MECHANISM	6-14
6.5.4	CUTTER MECHANISM	6-15
6.5.5	MASTER SET COVER SENSOR	6-16
6.6	DRUM.....	6-17
6.6.1	OVERVIEW.....	6-17
6.6.2	DRUM DRIVE MECHANISM	6-18
6.6.3	INK SUPPLY MECHANISM	6-19
6.6.4	INK ROLLER MECHANISM.....	6-20
6.6.5	INK SUPPLY CONTROL	6-21
6.6.6	DETECTION OF MASTERS ON THE DRUM.....	6-22
6.7	PAPER FEED	6-23
6.7.1	OVERVIEW.....	6-23
6.7.2	PAPER FEED MECHANISM	6-24
6.7.3	PAPER FEED / SEPARATION PRESSURE MECHANISM.....	6-25
6.7.4	REGISTRATION ROLLER MECHANISM	6-26
6.7.5	REGISTRATION SENSOR CLEANING.....	6-28
6.7.6	PRINTING PRESSURE MECHANISM	6-29
6.7.7	RE-FEEDING MECHANISM	6-29
6.7.8	PAPER TABLE MECHANISM.....	6-30
6.8	PAPER DELIVERY	6-32
6.8.1	OVERVIEW.....	6-32
6.8.2	PAPER DELIVERY UNIT DRIVE MECHANISM	6-33
6.8.3	PAPER SEPARATION FROM THE DRUM	6-34
6.8.4	EXIT PAWL DRIVE MECHANISM	6-35

6.9 TIMING CHART	6-37
6.9.1 MASTER EJECT / MASTER FEED	6-37
6.9.2 MASTER WRAPPING	6-38
6.9.3 PRINTING.....	6-39
7. POINT TO POINT DIAGRAM	7-1
Location Map.....	7-2
Section A.....	7-3
Section B.....	7-4
Section C	7-5
Section D	7-6
Section E.....	7-7
SPECIFICATIONS.....	SPEC-1
1. GENERAL SPECIFICATIONS.....	SPEC-1

1. INSTALLATION

1.1 INSTALLATION REQUIREMENTS

Carefully select the installation location because environmental conditions greatly affect machine performance.

1.1.1 OPTIMUM ENVIRONMENTAL CONDITION

1. Temperature: 10 to 30 °C (50 to 86 °F)
2. Humidity: 20 to 90 %RH
3. Install the machine on a strong and level base. The machine must be level within 5mm (0.2") both front to rear left to right.

1.1.2 ENVIRONMENTS TO AVOID

1. Locations exposed to direct sunlight or strong light (more than 1,500 lux).
2. Dusty areas
3. Areas containing corrosive gases.
4. Locations directly exposed to cool air from an air conditioner or reflected heat from a space heater. (Sudden temperature changes from low to high or vice versa may cause condensation within the machine.)

1.1.3 POWER CONNECTION

1. Securely connect the power cord to a power source.
2. Make sure that the wall outlet is near the machine and easily accessible.
3. Make sure the plug is firmly inserted in the outlet.
4. Avoid multi-wiring
5. Do not pinch the power cord.

1.1.4 MINIMUM SPACE REQUIREMENTS

Place the machine near a power source, providing minimum clearance as shown below.

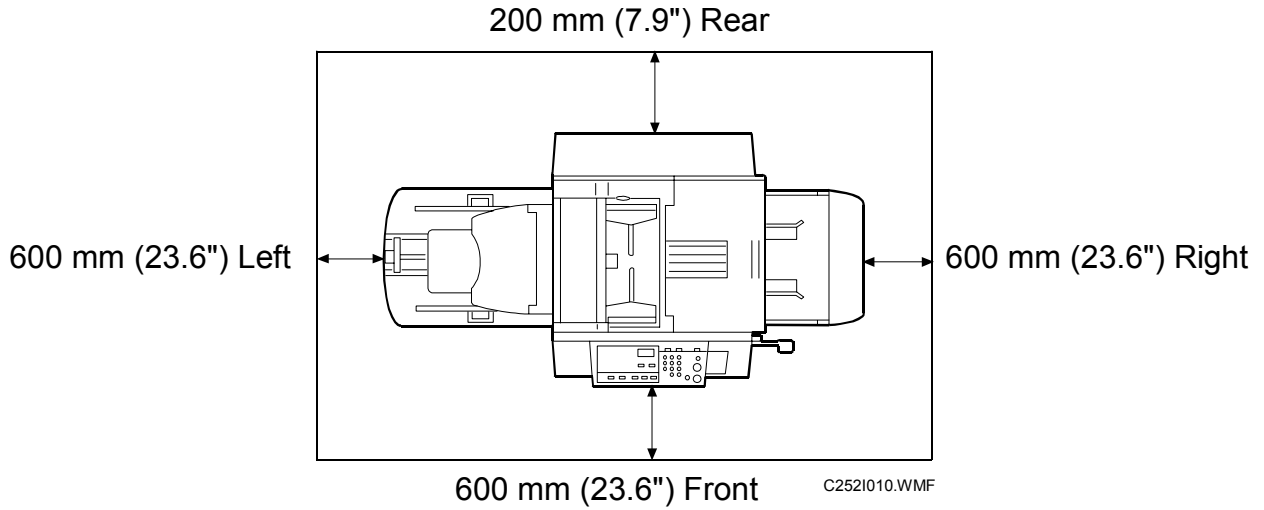

1.1.5 DIMENSIONS

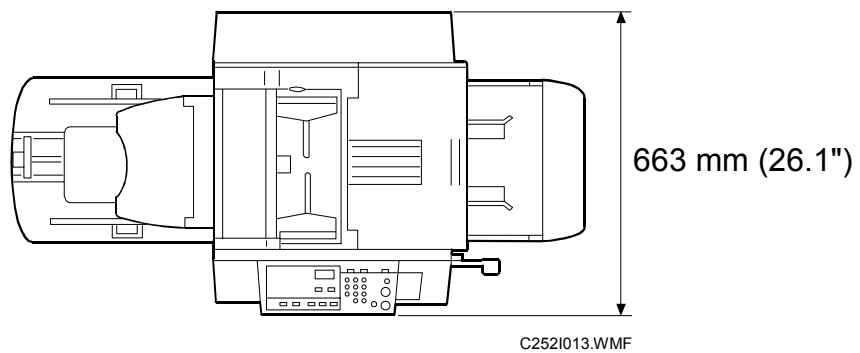
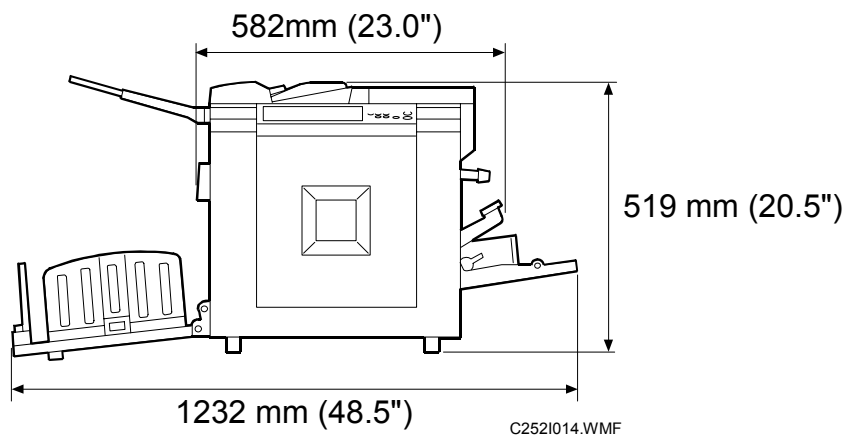

1.2 INSTALLATION PROCEDURE

1.2.1 MAIN BODY

Accessory Check

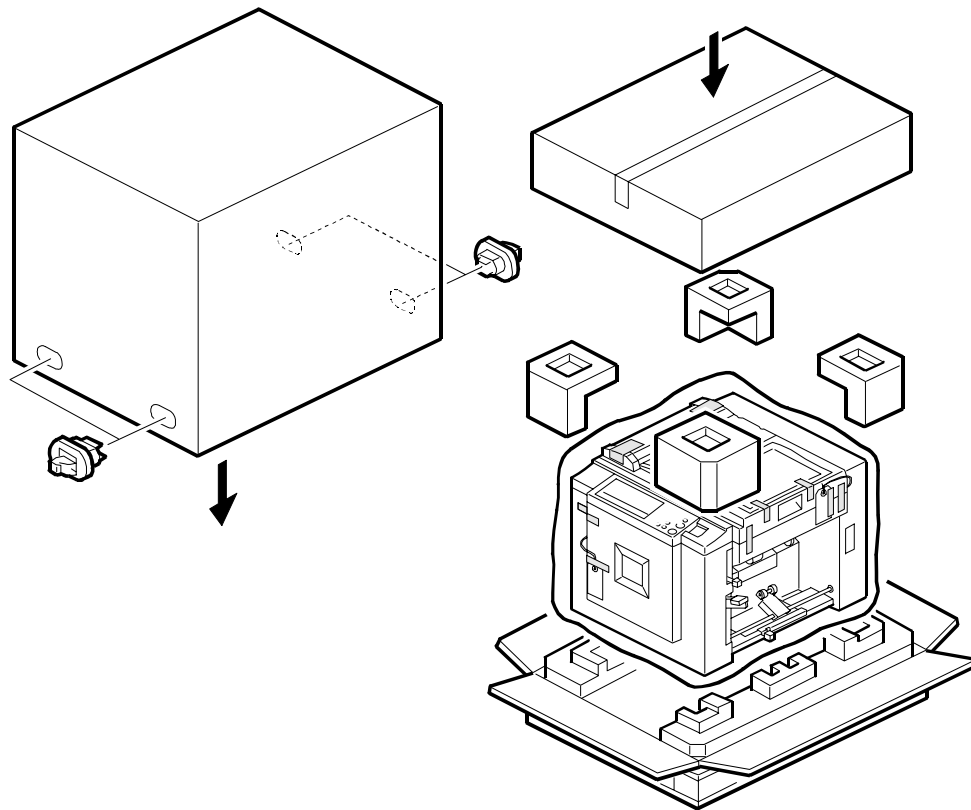

C2521001.WMF

Make sure that you have all the accessories listed below.

Description	Q'ty
1. Master Spool.....	2
2. Paper Feed Side Pad.....	2
3. Operating Instructions.....	1
4. NECR (Ricoh version only).....	1
5. Model Name Plate (C252-72 and C252-92).....	1 set
6. Paper Table	1 set
7. Paper Delivery Table	1 set

Installation Procedure

⚠ CAUTION
To avoid serious injury, do not connect the power plug to the machine until you are instructed to do so.

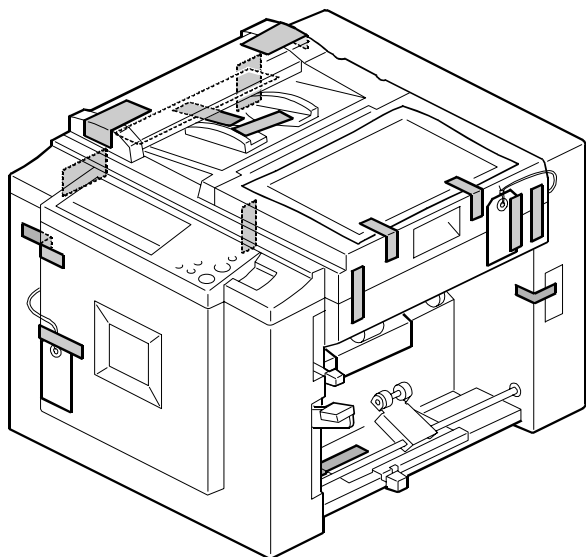

C2521002.WMF

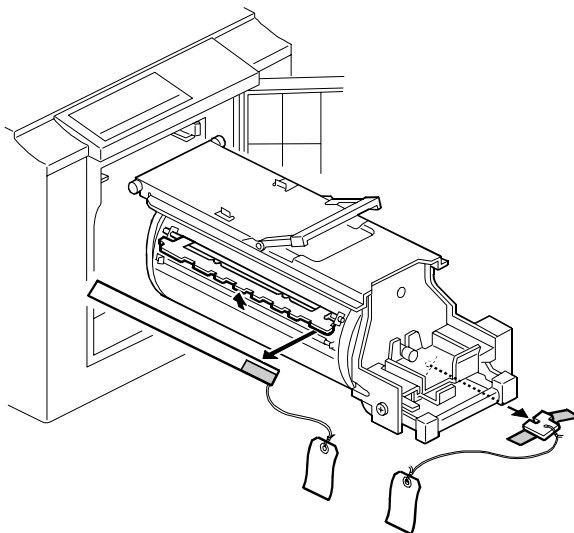

C2521004.WMF

1. Unpack the machine and remove all the wrapping.



2. Remove all filament tape and string securing the covers and units as shown above.

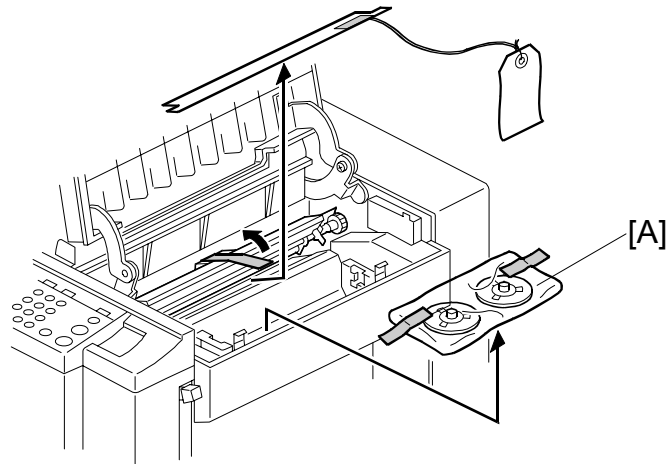

C2521009.WMF

3. Open the right side cover, and take out the accessory bag [A].

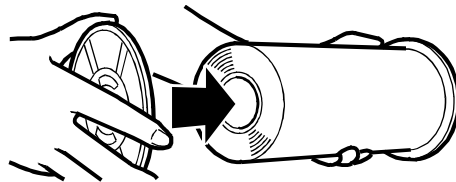

C2521902.WMF

4. Insert both spools into a new master roll.

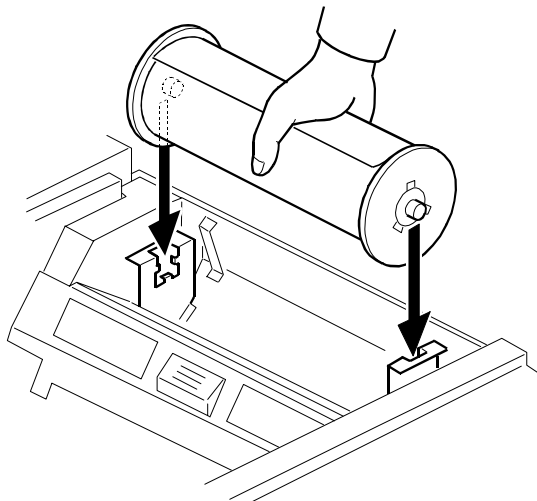

C2521018.WMF

5. Install the master roll.

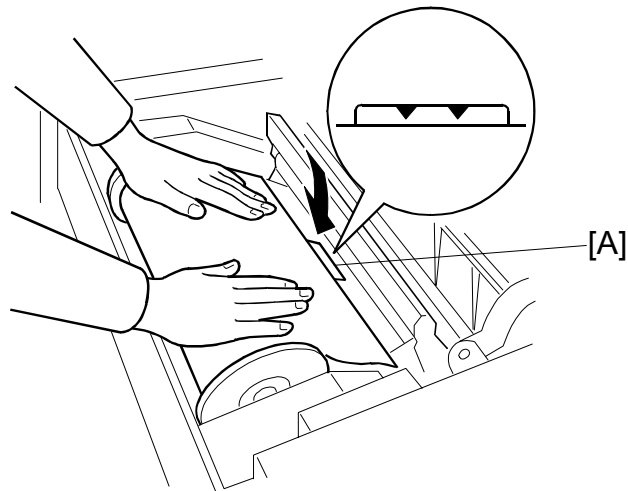

C252I019.WMF

6. Open the master making unit cover, and insert the leading edge of the master roll under the platen roller. The arrows [A] indicate the correct position of the master leading edge.

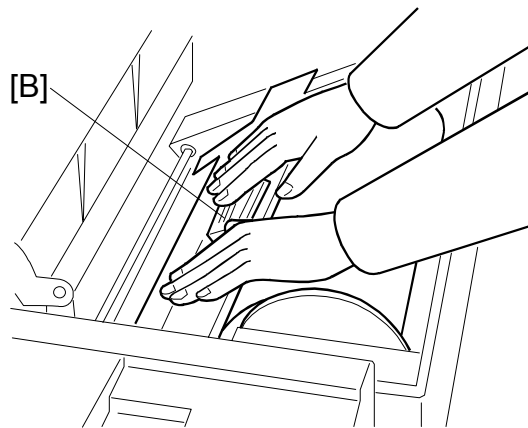

C252I020.WMF

7. Close the master making unit cover [B] using both hands until it clicks into place.
8. Close the right side cover.

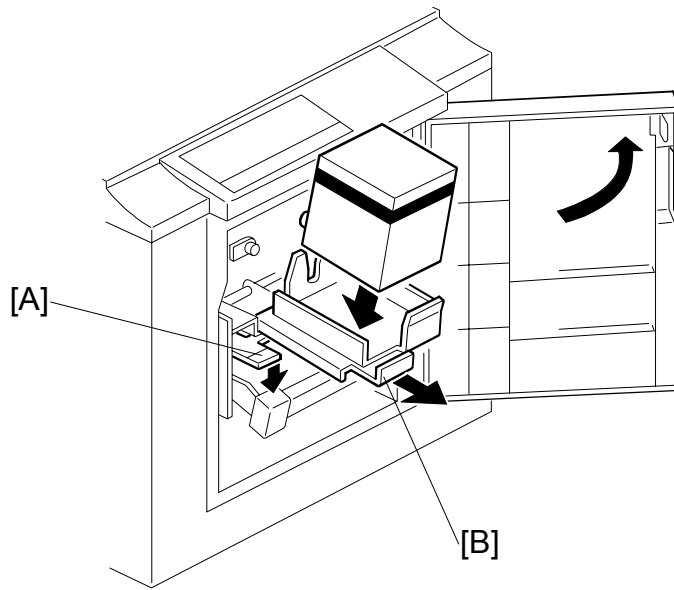

C252I016.WMF

9. Open the front door.
10. Release the ink holder lock lever [A] and pull out the ink holder [B].
11. Insert a new ink cartridge.

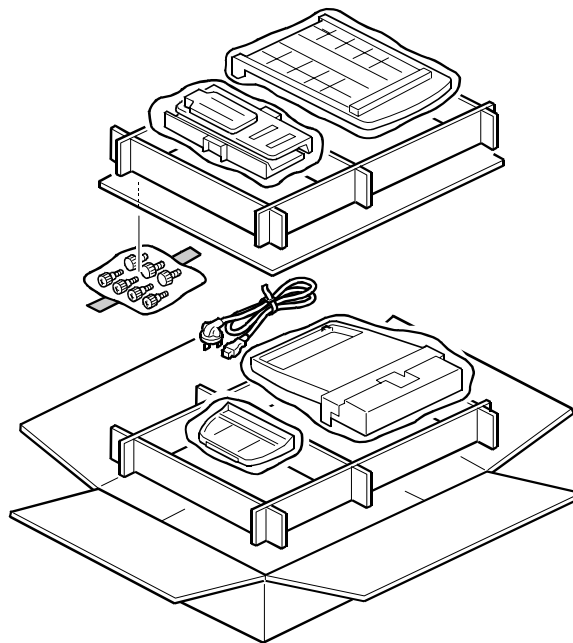

C252I003.WMF

12. Take the paper table and paper delivery table out of the box.

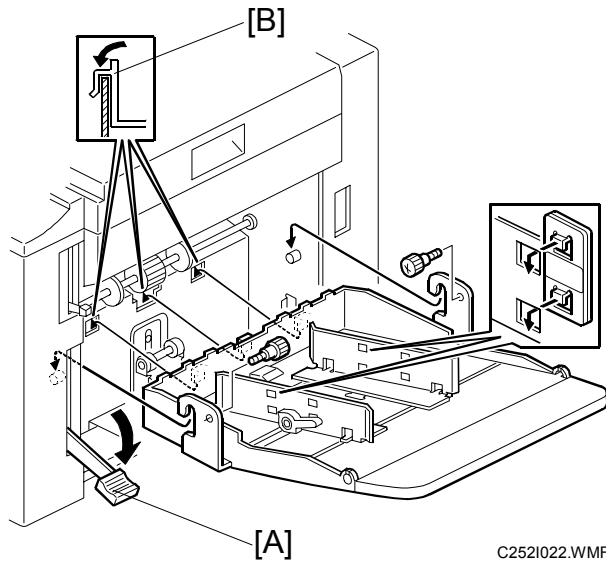

13. Lower the paper feed tray adjustment lever [A], and install the paper table. (⚙ x 2)

- NOTE:** 1) When installing the paper table, make sure that the hooks [B] are set firmly.
- 2) Two side fence friction pads are included as accessories. They are not used normally, but if paper multi-feed frequently occurs or thin paper is used, the side fence friction pads can be installed to apply stopping pressure to the paper.

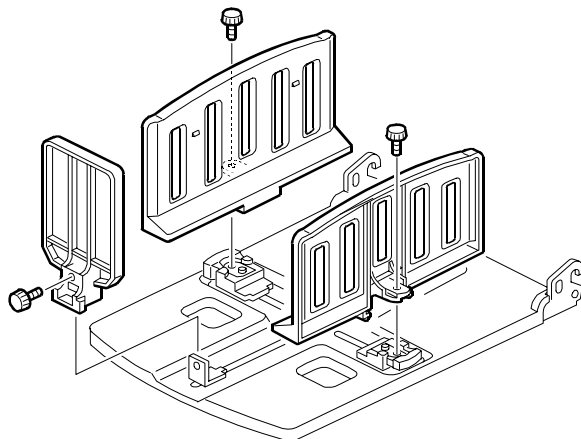

14. Attach the side and end fences, as shown. (⚙ x 3)

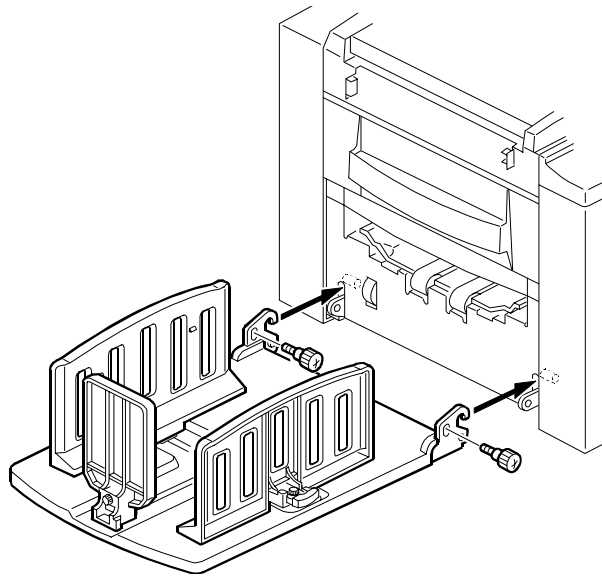

C2521007.WMF

15. Install the paper delivery table. (⌀ x 2)

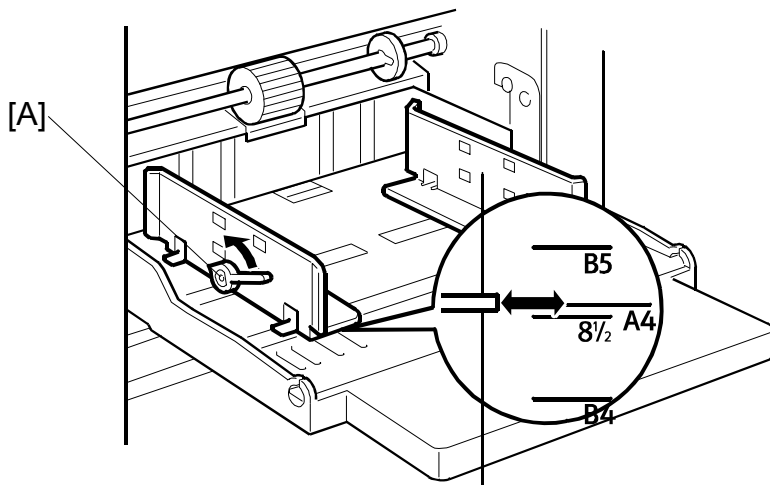

C2521015.WMF

16. Release the paper feed side plate lock levers [A] and adjust the side plates to match the paper size.

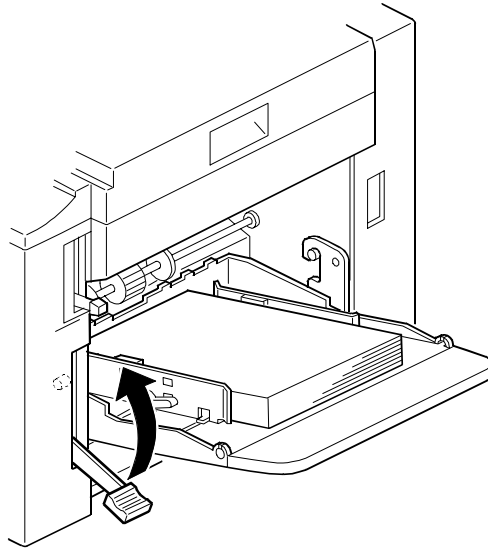

C2521021.WMF

17. Load paper into the paper table.
18. Shift the paper feed tray adjustment lever [A] up to the paper feeding position.

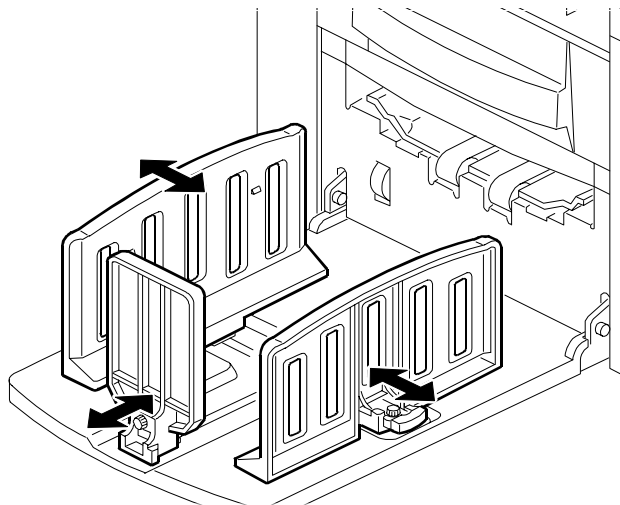

C2521017.WMF

19. Adjust the side and end fences of the paper delivery table to match the paper size.

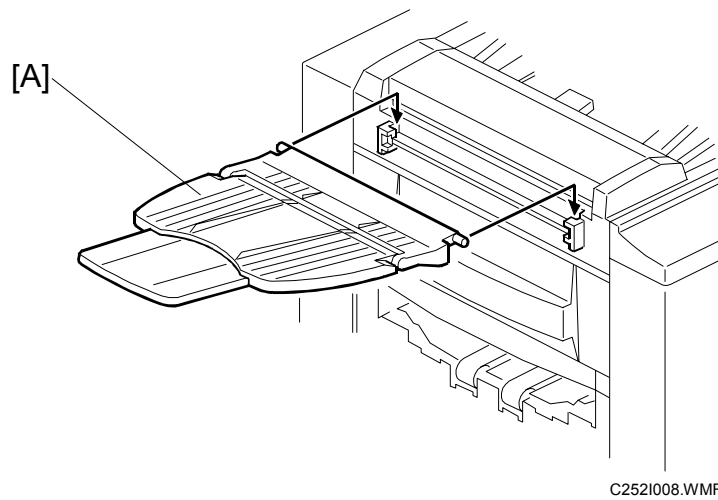

20. Attach the original table [A].
21. Firmly insert the power plug in the outlet.
22. Turn on the main switch.
23. Press the clear/stop key while holding down the 0 key, to supply ink to the drum.
24. Make some test copies.

1.2.2 ADDITIONAL DRUMS (OPTION)

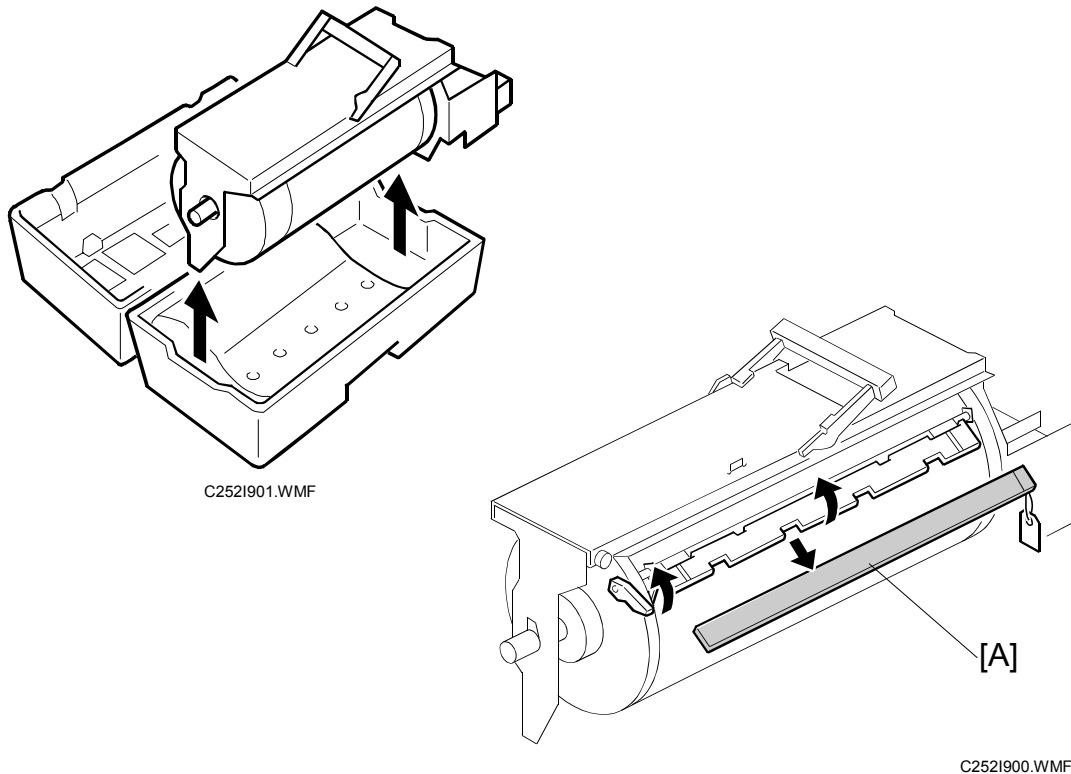

There are two types of drum units:

B4 size Color Drum: Color Drum Type 7 (M)

LG size Color Drum: Color Drum Type 7 (S)

1. Remove the protective sheet [A] from the drum unit.
2. Remove the tape securing the ink holder.
3. Attach a color indicator decal to the drum case. The decal must be the same color as the ink in use.
4. Remove the drum unit.
5. Leave the master wrapped around the removed drum to protect the drum from dust and from drying.
6. Keep the removed drum unit in the drum case.
7. Install the drum unit.
8. Remove the ink cartridge cap.
9. Insert the ink cartridge in the ink holder.

1.2.3 INTERFACE BOARD (OPTION)

Accessory Check

Check the quantity and condition of the accessories in the box against the following list:

Description	Q'ty
1. Interface Board	1
2. Interface Cable.....	1
3. Screw M3 x 6	2
4. Lock Screw	2
5. Washer.....	2

Installation Procedure

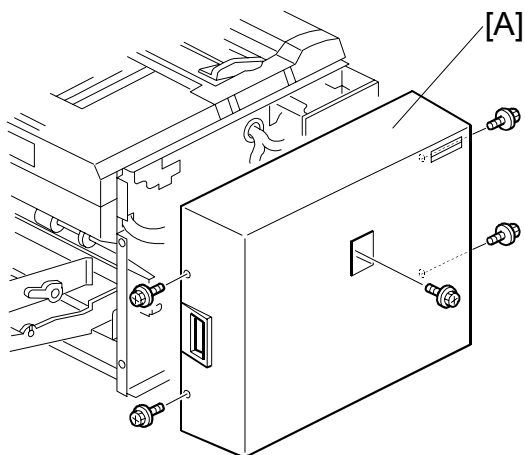

C2521011.WMF

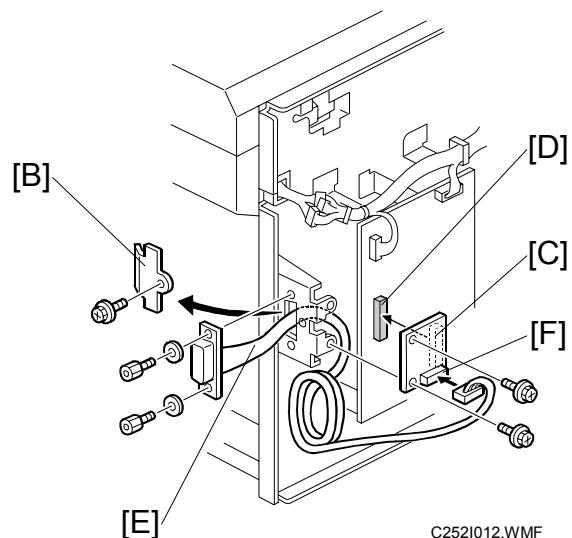

C2521012.WMF

1. Remove the rear cover [A]. (⚙ x 5)
2. Remove the I/F connector cover [B]. (⚙ x 1)
3. Connect the I/F board [C] (accessories) to CN108 [D] on the MPU. (⚙ x 2)
4. Attach the cable [E] (accessories) to the connector bracket. (⚙ x 2)
5. Connect the connector [F] at the opposite end to the I/F board.
6. Re-install the rear cover.

2. PREVENTIVE MAINTENANCE

2.1 MAINTENANCE TABLE

The following items should be maintained periodically. There are two sets of intervals - one based on time and the other based on print count. For maintenance items with entries in both of them, use whichever comes first.

Symbol key: C: Clean, R: Replace, L: Lubricate, A: Adjust

⚠ WARNING
Turn off the main power switch and unplug the machine before performing any procedure in this section.

Preventive Maintenance

Item	Interval	Time				Print Counter					EM	Note
		6M	1Y	2Y	5Y	150K	300K	600K	1.2M	3M		
Scanner/Optics												
CIS		C	C	C	C						C	Dry Cloth
1st Feed Roller		C	C	C	C			C			C	Damp Cloth
2nd Feed Roller		C	C	C	C			C			C	Damp Cloth
Shading Plate (White Plate)		C	C	C	C							Dry Cloth Expected life is 10k masters.
Master Feed												
Thermal Head								C				Alcohol
Platen Roller		C	C	C	C			C				Alcohol
Drum Master Sensor								C			C	Dry Cloth
Paper Feed												
Paper Feed Roller		C	R	R	R		C	R	R	R		Damp Cloth
Friction Pad		C	R	R	R		R	R	R	R		Water or Alcohol
Press Roller		C	C	R	C				R		C	Alcohol
Exit Sensor		C	C	C	C							Dry Cloth
Registration Sensor		C	C	C	C		C					Dry Cloth
Registration Rollers							C					Water or Alcohol
Paper Delivery Unit Bushings								C L			C L	Motor Oil (SAE #20)
Paper Feed Clutch										R		

Item	Interval	Time				Print Counter					EM	Note
		6M	1Y	2Y	5Y	150K	300K	600K	1.2M	3M		
Drum and Ink Supply												
Cloth Screen			R					R				
In/Outside of Drum	C	C	C	C			C				C	Damp Cloth
Ink Nozzle	C	C	C	C			C					Damp Cloth
Drum Clamper Plate/Magnet					C							Water or Alcohol

3. REPLACEMENT AND ADJUSTMENT

3.1 GENERAL CAUTION

CAUTION

Turn off the main power switch and unplug the machine before attempting any of the procedures in this section.

3.2 COVERS

3.2.1 PANEL / FRONT COVERS

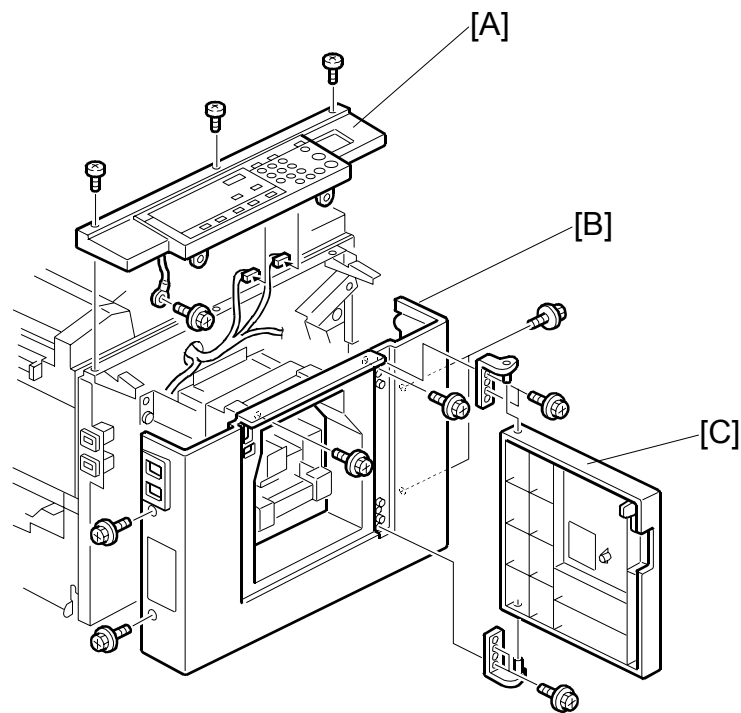

C252R001.WMF

[A]: Panel (⚙ x 4, ⚙ x 2)

[B]: Front cover (⚙ x 6)

[C]: Front door (⚙ x 4)

3.2.2 REAR COVER

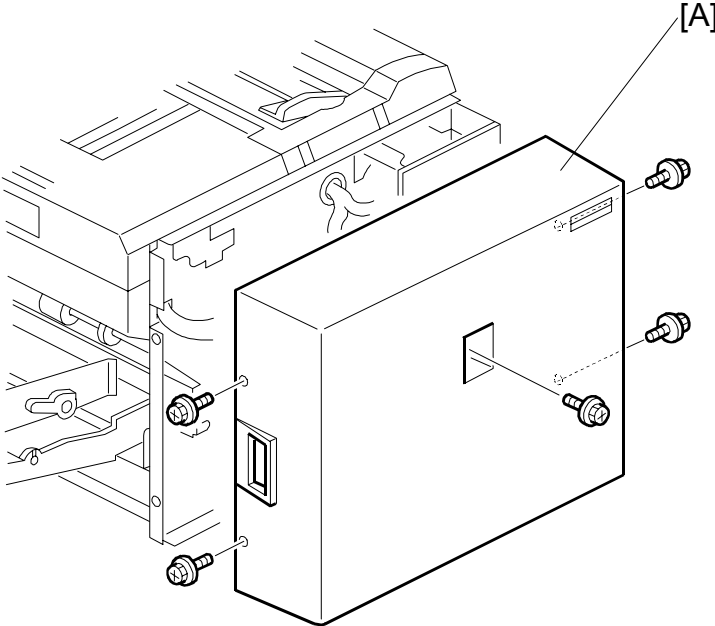

C252R920.WMF

[A]: Rear cover (⌀ x 5)

3.3 BOARDS

3.3.1 MPU

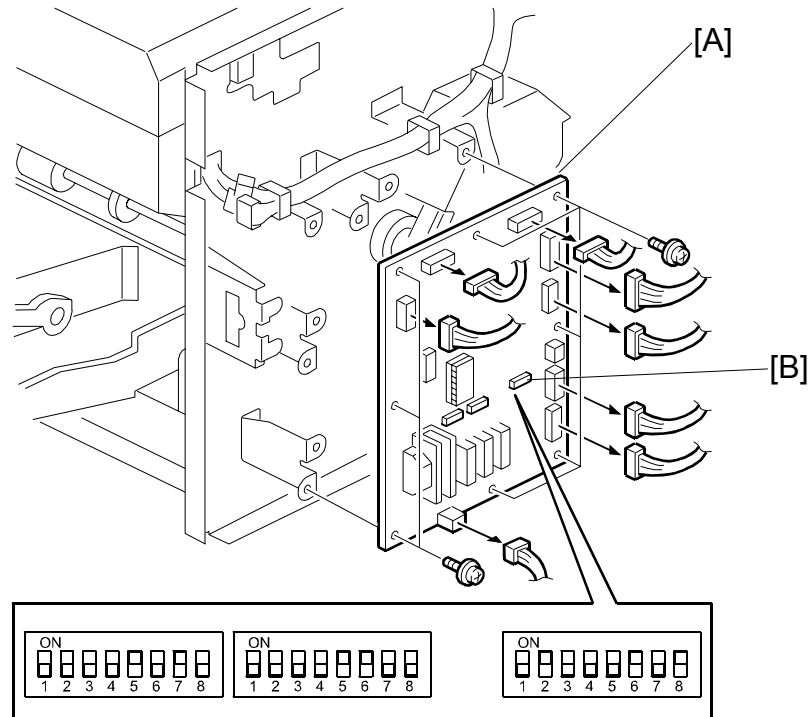

C252R002.WMF

- Rear cover (☛ 3.2.2)
- [A]: MPU (🔧 x 8, 📏 x 8)

- NOTE:** 1) Check the dip switch settings on the old MPU and make the dip switch settings [B] the same on the new MPU.
- 2) Adjust the master end sensor (☛ 3.5.4) after installing the new MPU.
- 3) Adjust the ink detection (☛ 3.9.6) after installing the new MPU.
- 4) Ensure that the EPROM on the MPU contains the correct firmware.

Replacement
Adjustment

3.3.2 PSU

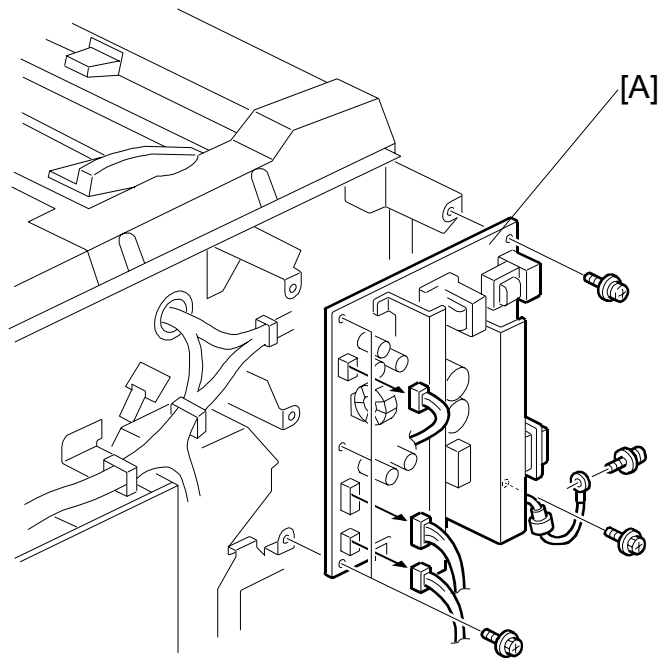

C252R003.WMF

- Rear cover (☛ 3.2.2)
- [A]: PSU (⚙ x 6, ⚙ x 3)

NOTE: When the PSU is replaced, the thermal head voltage returns to the default. Adjust the thermal head voltage (☛ 3.5.3) after installing the new board.

3.4 SCANNER

3.4.1 COVERS

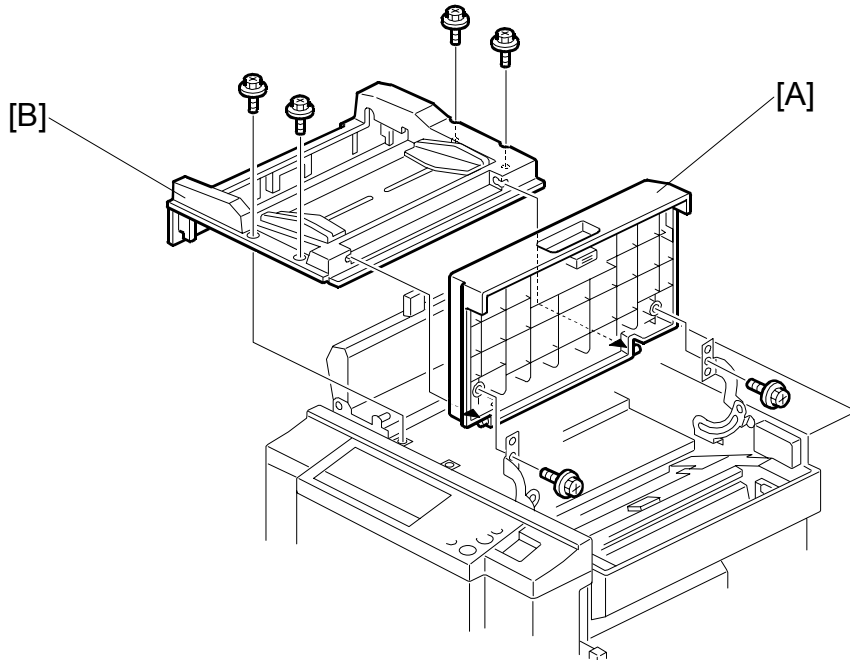

C252R004.WMF

[A]: Right side cover (⚙ x 2)

[B]: Scanner cover (⚙ x 4)

Replacement
Adjustment

3.4.2 1ST, 2ND FEED ROLLER / CIS (CONTACT IMAGE SENSOR)

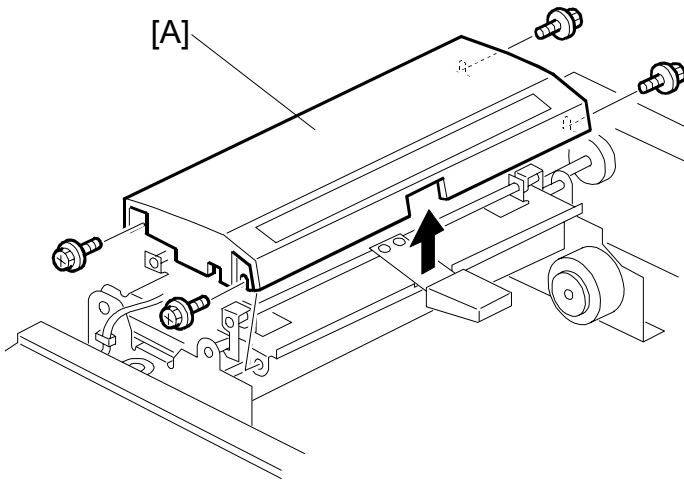

C252R038.WMF

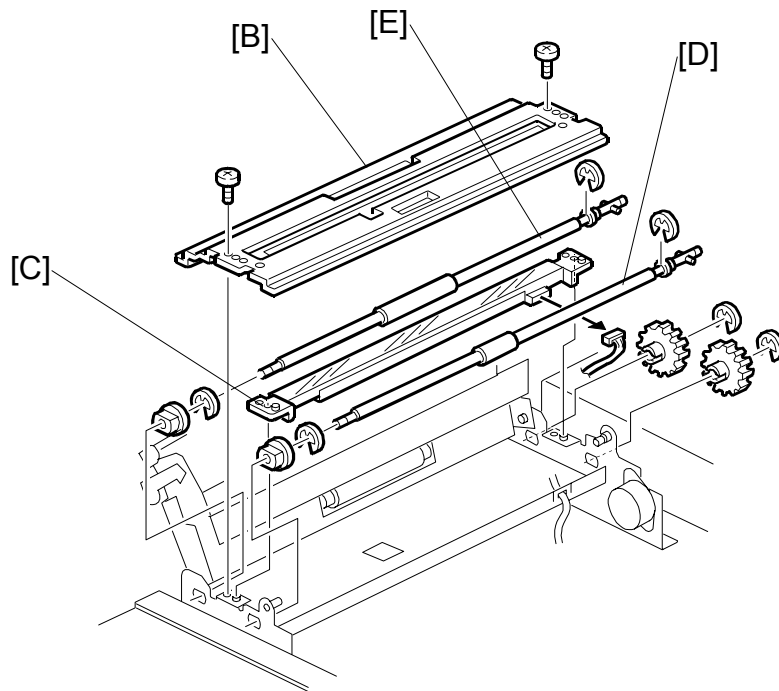

C252R005.WMF

- [A]: Upper cover (🔩 x 4)
- [B]: Guide plate (🔩 x 2)
- [C]: CIS (📡 x 1)
- [D]: 1st feed roller (Ⓒ x 3)
- [E]: 2nd feed roller (Ⓒ x 3)

3.4.3 DOCUMENT SENSOR

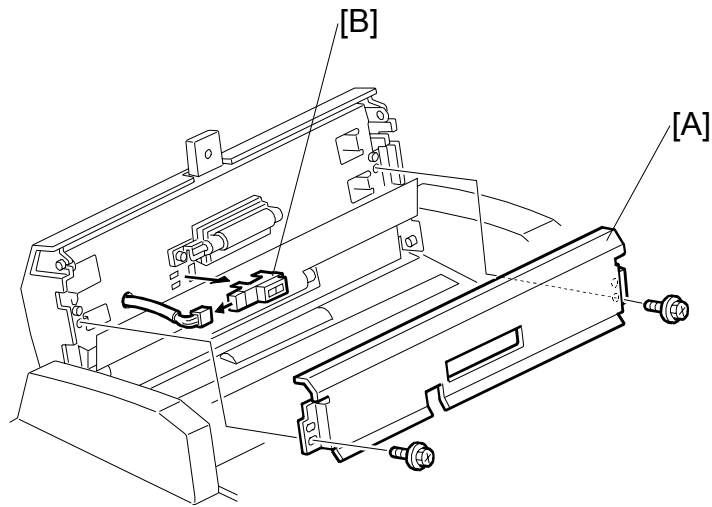

C252R006.WMF

Replacement
Adjustment

- [A]: Upper guide plate (🔩 x 2)
- [B]: Document sensor (🔌 x 1)

3.4.4 SCANNER MOTOR

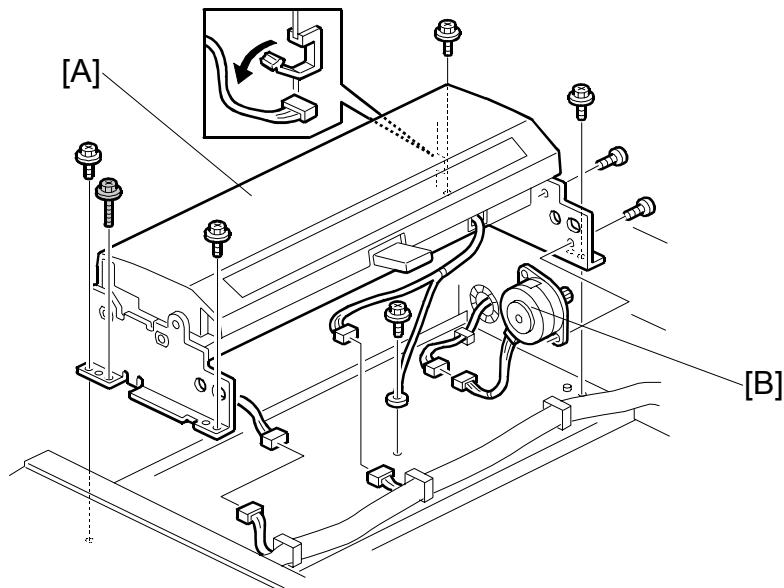

C252R007.WMF

- [A]: Scanner unit (🔩 x 5, 🔌 x 3)
- [B]: Scanner motor (🔩 x 2)

3.5 MASTER FEED

3.5.1 MASTER MAKING UNIT

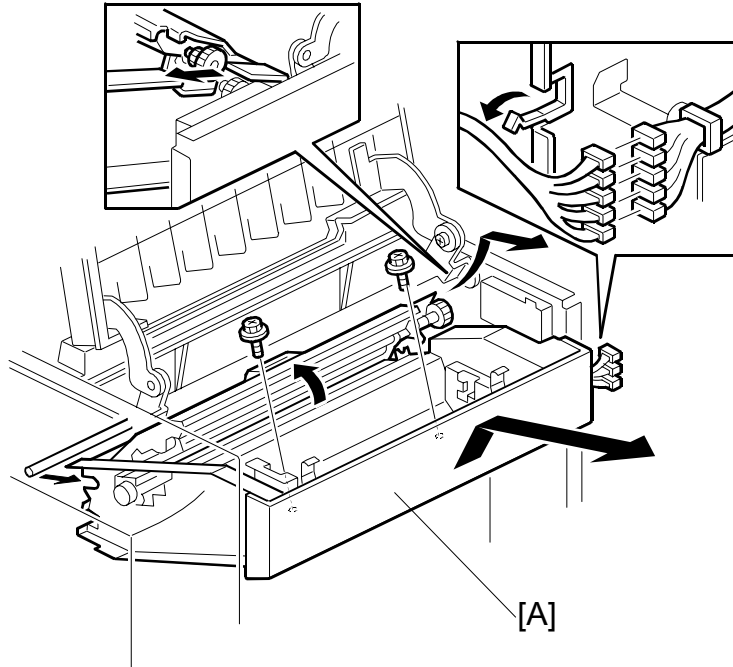

C252R008.WMF

[A]: Master making unit (🔩 x 2, 📦 x 5)

3.5.2 THERMAL HEAD

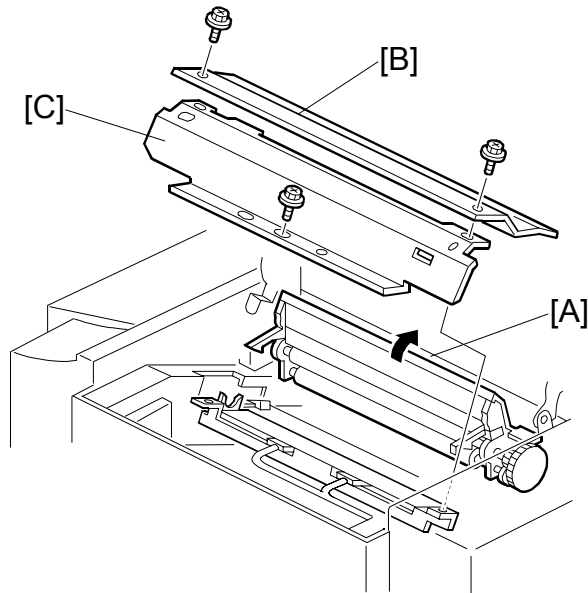

C252R009.WMF

Replacement
Adjustment

- Master making unit (☛ 3.5.1)
- [A]: Open the platen roller unit.
- [B]: Thermal head upper cover (🔩 x 2)
- [C]: Thermal head side cover (🔩 x 1)

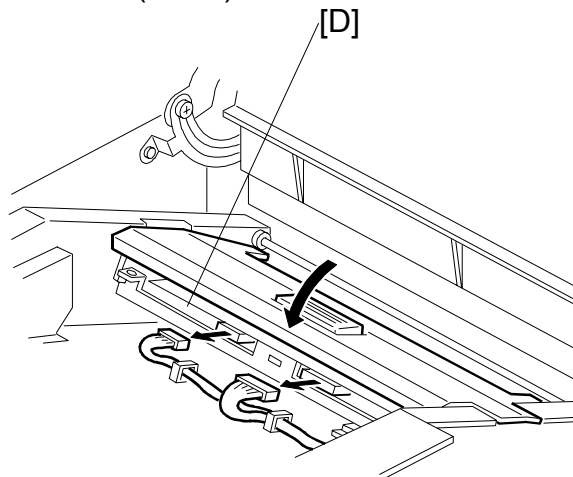

C252R010.WMF

- Close the platen roller unit.
- [D]: Thermal head (🔩 x 2)

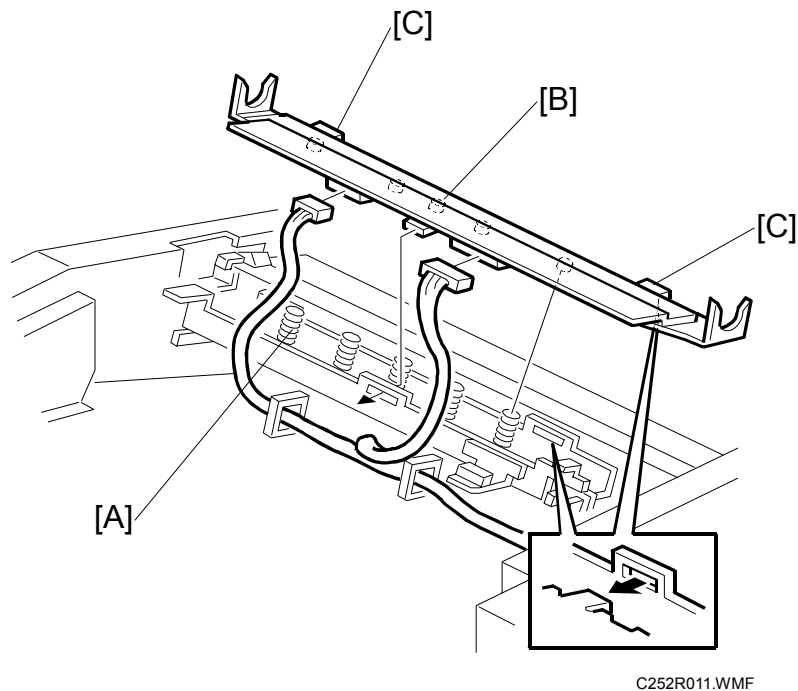
Installation

If the following remarks are not followed, the thermal head will be installed incorrectly.

1. Fit the base's springs [A] over the protrusions [B] on the underside of the thermal head (5 points).
2. While fitting the tops of the springs [A] over the protrusions on the underside of the thermal head, hook the lock pawls [C] of the thermal head onto the base (3 lock pawls). Make sure to set the front side (the paper table side) first.
3. Make sure that all protrusions are properly fitted into the springs.

- NOTE:**
- 1) Adjust the thermal head voltage (➔3.5.3) after installing the new thermal head.
 - 2) Don't touch the surface with bare hands. (If you touch it, clean the surface with alcohol.)
 - 3) Don't touch the terminals of the connectors with bare hands.

3.5.3 THERMAL HEAD VOLTAGE ADJUSTMENT

⚠ CAUTION

This adjustment is always required when the thermal head or PSU has been replaced.

Purpose: To maintain master making quality and extend the lifetime of the thermal head.

Standard: Refer to the voltage value (X) printed on the thermal head. The value varies from one thermal head to another.

The adjustment voltage should be between X and X - 0.1 V.

Tools: Circuit tester

- Rear cover (☛ 3.2.2)
- Read the voltage value on the decal on the thermal head.

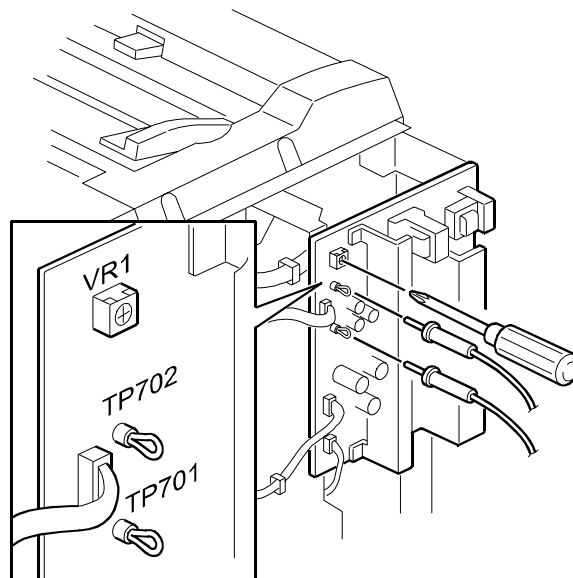

C252R012.WMF

1. Connect the positive terminal of a circuit tester to TP701 and the negative terminal to TP702 on the PSU.
CAUTION: If the output and ground terminals touch each other, the board will be damaged.
2. Connect the power plug, and turn on the main switch to access SP mode.
3. Select SP2-41 (Thermal head signal output).
4. Press the # key. Power is continuously supplied to the thermal head, which could damage the thermal head, so press the clear/stop key if you cannot finish the adjustment quickly.
A beeper sounds while the power is being supplied.
5. Measure the voltage, and turn VR1 on the PSU until the value is between "+0" and "-0.1" volts from the value on the thermal head decal.

3.5.4 MASTER END SENSOR ADJUSTMENT

Purpose: To ensure that the sensor detects the end mark (a solid black area) on the master roll.

Standard: 2.0 ± 0.1 volts

Tools: The core of a used master roll (the core just before a master end display appears)

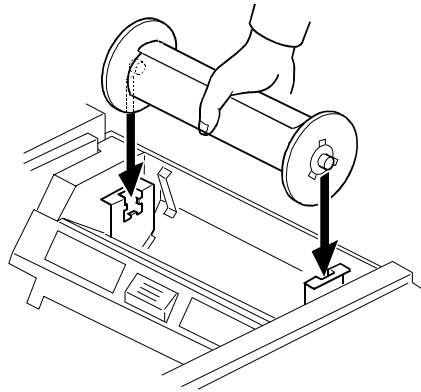

C252R900.WMF

- Rear covers (☛3.2.2)

1. Place the core inside the master making unit, and close the master making cover.
2. Connect the power plug, and turn on the main switch.
3. Access SP6-41.

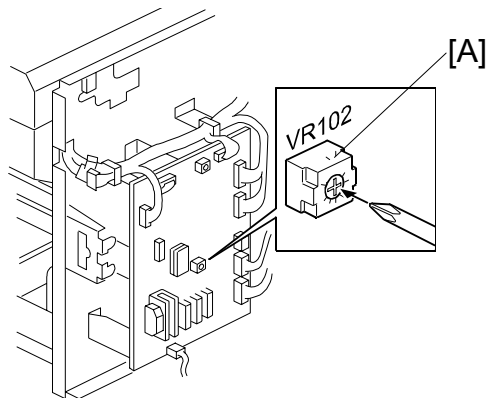

C252R039.WMF

4. Turn VR102 [A] on the MPU board until the display is 2.0 ± 0.1 volts.

3.6 MASTER EJECT

3.6.1 MASTER EJECT UNIT

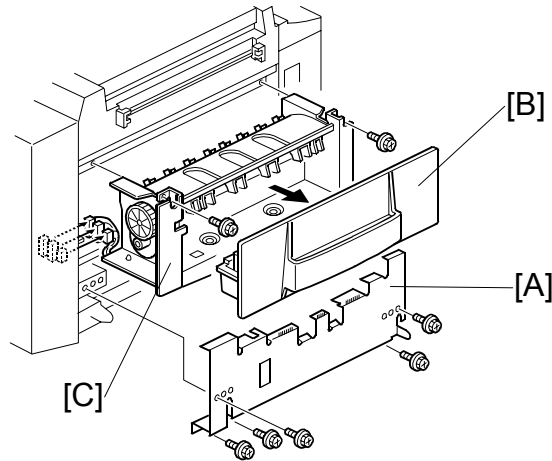

C252R013.WMF

- [A]: Paper delivery cover (🔩 x 5)
- [B]: Master eject box
- [C]: Master eject unit (🔩 x 2, 📐 x 3)

3.6.2 MASTER EJECT ROLLERS

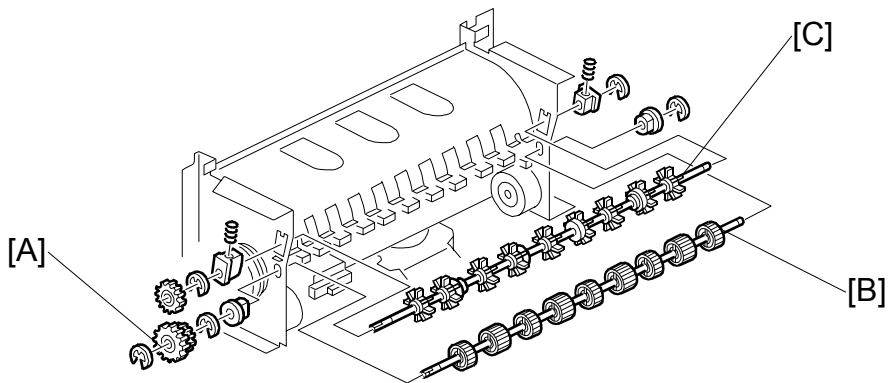

C252R014.WMF

- Master eject unit (➔ 3.6.1)
- [A]: Gears (Ⓒ x 1)
- [B]: Lower master eject roller (Ⓒ x 2)
- [C]: Upper master eject roller (Ⓒ x 2, spring)

3.7 PAPER FEED

3.7.1 PAPER FEED ROLLER / FRICTION PAD

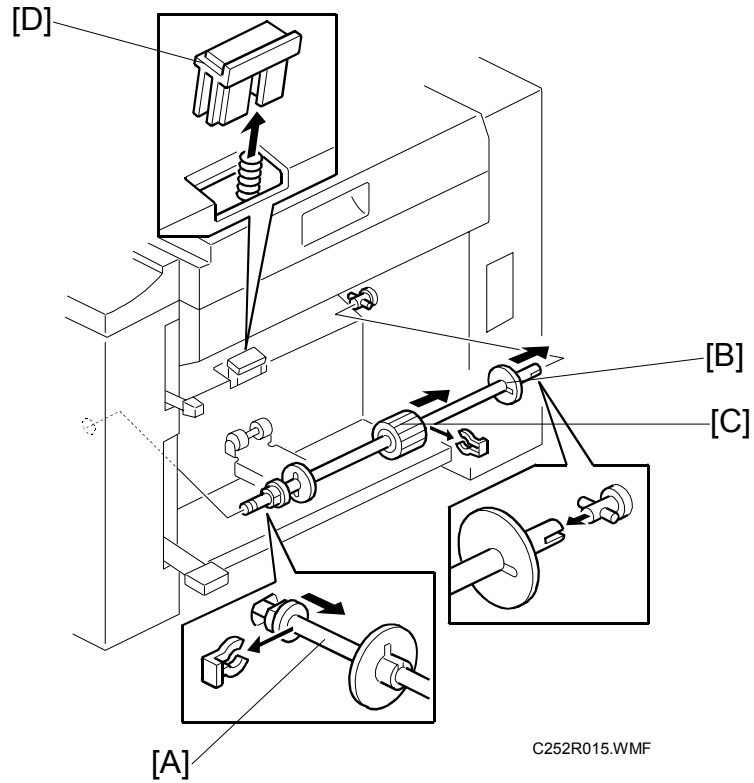

- [A]: Paper feed roller unit (☺ x 1)
- [B]: Paper guide
- [C]: Paper feed roller (☺ x 1)
- [D]: Friction pad

3.7.2 PAPER FEED PRESSURE ADJUSTMENT

The position of the spring can be changed in order to change the amount of pressure exerted by the paper tray adjustment plate.

This adjustment can be done:

- When feeding special paper (especially thick paper and thin paper)
- When the customer is experiencing feed problems.

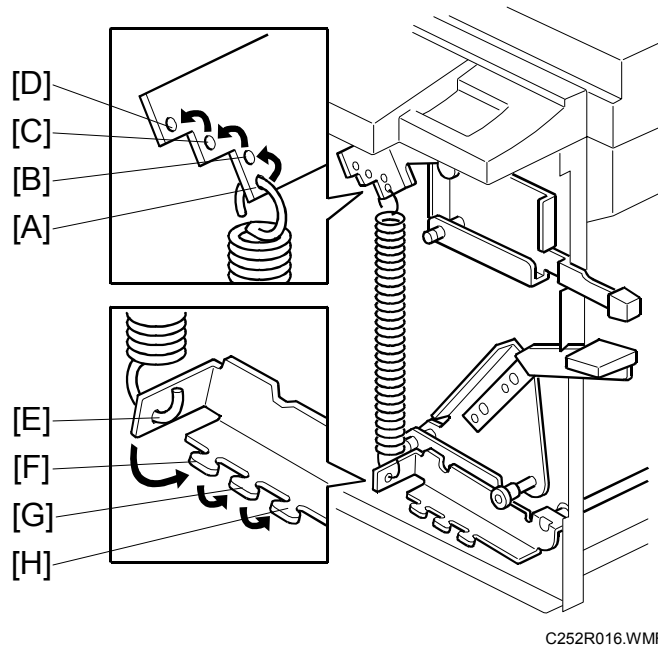

Replacement
Adjustment

- Front cover (☛ 3.2.1)

Increase the feed pressure: [A] → [B] → [C] → [D]

Decrease the feed pressure: [E] → [F] → [G] → [H]

Default position: [A] and [E] positions

3.7.3 PAPER SEPARATION PRESSURE ADJUSTMENT

The position of the screw can be changed in order to change the amount of pressure exerted by the friction pad.

This adjustment can be done:

- When feeding special paper, especially thick paper
- When the customer is experiencing feed problems.

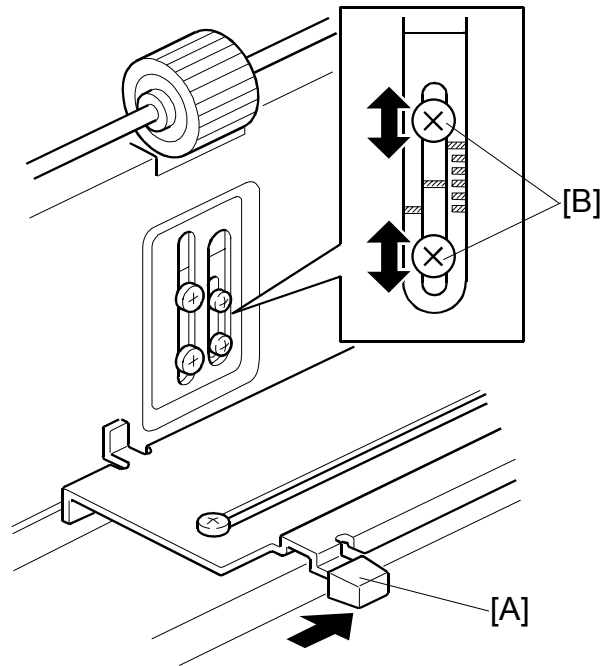

C252R017.WMF

- Remove the paper table
- Move the separation pressure slider [A] to position 1 (right end).

Increase the paper separation pressure: Move up the screws [B]

Decrease the paper separation pressure: Move down the screws [B]

Default position: lowest position

For more details: See section 6.7.3

3.8 PRINTING

3.8.1 PRESS ROLLER

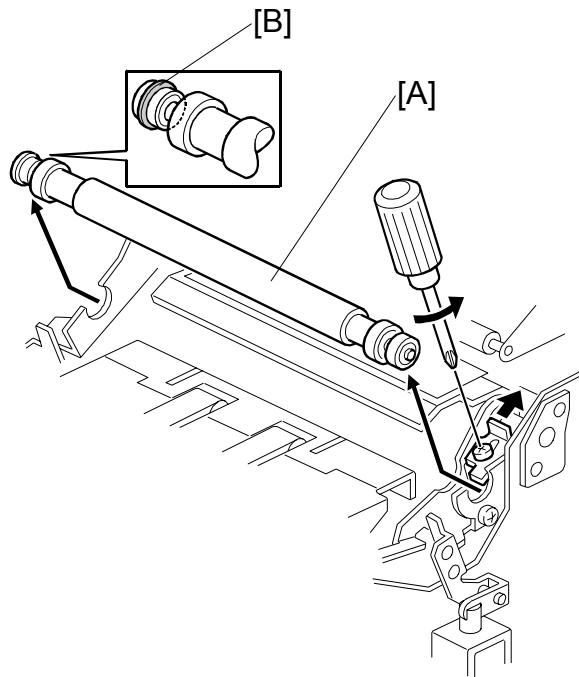

C252R018.WMF

Replacement
Adjustment**⚠ CAUTION**

Take care to avoid possible injury. If the printing pressure release arms disengage, the press roller will be pulled upwards suddenly.

- Remove the drum
- [A]: Press roller (🔧 x 1)

The bearings on the rear and front differ. During installation, ensure that the bearing with the stopper [B] is positioned towards the rear of the machine.

3.8.2 PAPER REGISTRATION ROLLER

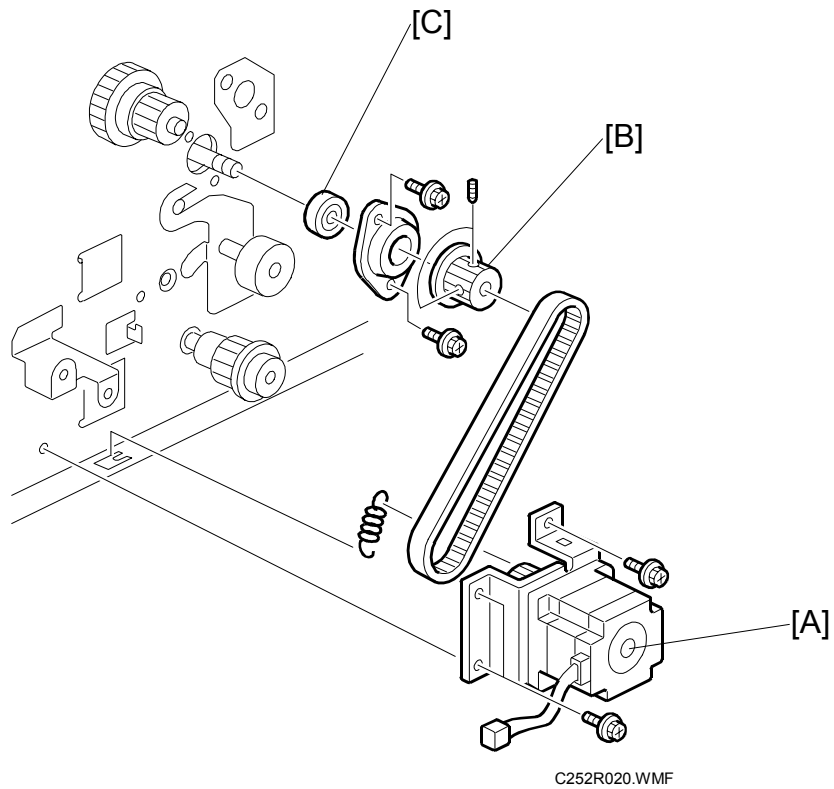

- Remove the paper table
 - Front cover (☛ 3.2.1)
 - Rear cover (☛ 3.2.2)
 - MPU (☛ 3.3.1)
- [A]: Registration motor (spring, ⚙ x 3, belt)
- [B]: Gear
- [C]: Bearing (⚙ x 2)

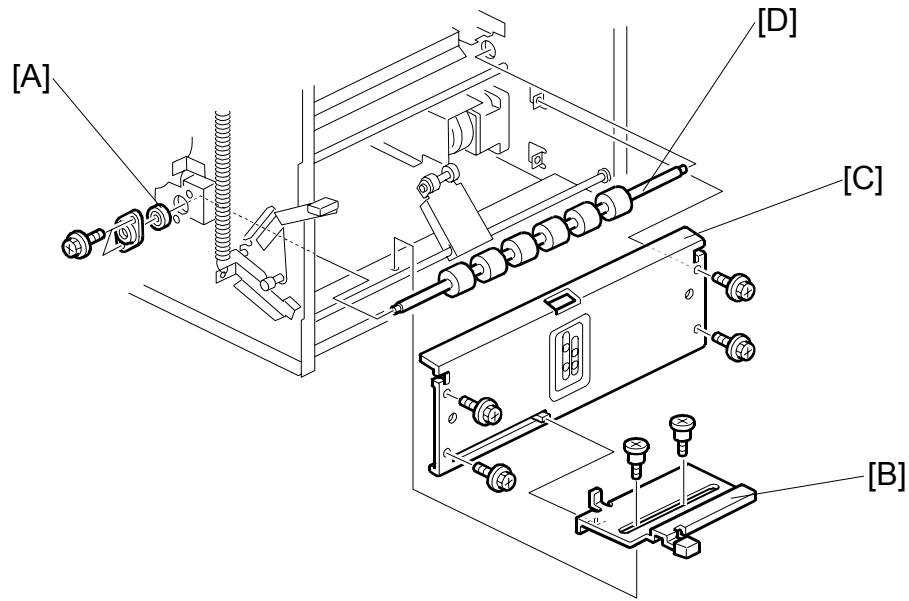

C252R021.WMF

- [A]: Bearing (🔩 x 2)
- [B]: Slider bracket (🔩 x 2)
- [C]: Plate (🔩 x 4)
- [D]: Registration roller

Replacement
Adjustment

3.8.3 PRESS ROLLER RELEASE LEVER ADJUSTMENT

Purpose: To maintain the correct clearance between the press roller arms and press roller lock levers. This ensures that the press roller is correctly released and pressed against the drum when the press roller release solenoid is energized.

Standard: 0.7 to 1.2 mm

Tools: Thickness gauge

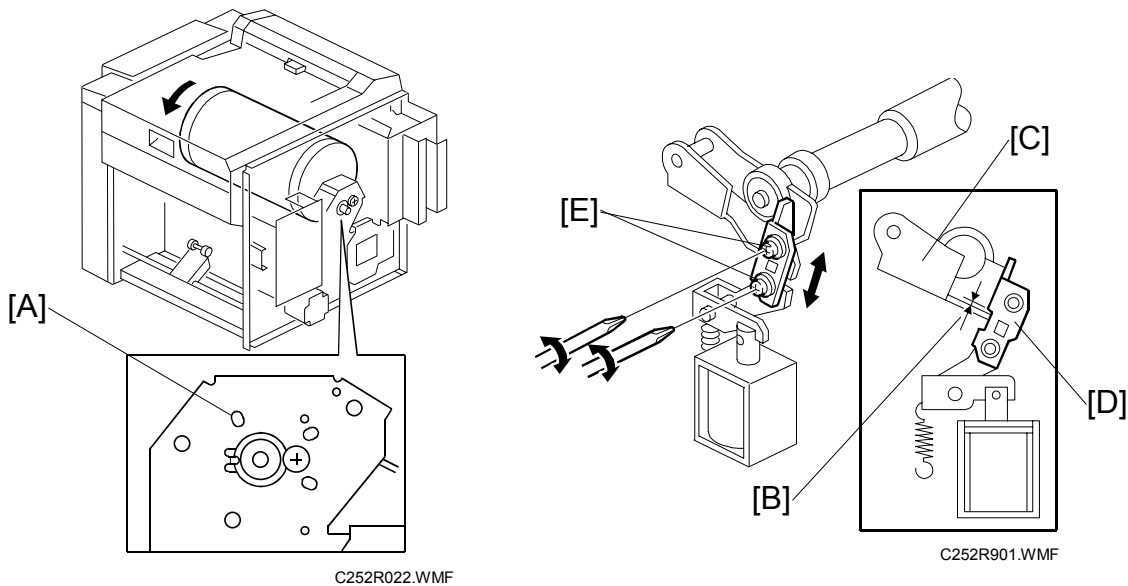

- Front cover (☛ 3.2.1)
 - Rear covers (☛ 3.2.2)
1. Turn the drum manually until the drum master clamper on the drum moves into the lowest position. (This is when the high points of the cams on the drum flanges meet with the cam followers on both ends of the press roller.)
 - To find out the correct position of the drum for the adjustment, look at the rear end of the drum shaft. The recess on the drum drive gear meets the hole [A] in the bracket when the drum is in the correct position.
 2. Using a thickness gauge, measure the clearance [B] between the press roller arm [C] and the press roller lock lever [D] (rear side). It should be between 0.7 and 1.2 mm.
 3. If it is not correct, adjust the position of the press roller lock lever after loosening the two screws [E].
 4. Repeat steps 2 and 3 for the front side.

3.8.4 PRINTING PRESSURE ADJUSTMENT

Purpose: To make better print results without decreasing the run length.

Standard: Within 10 ± 0.5 mm

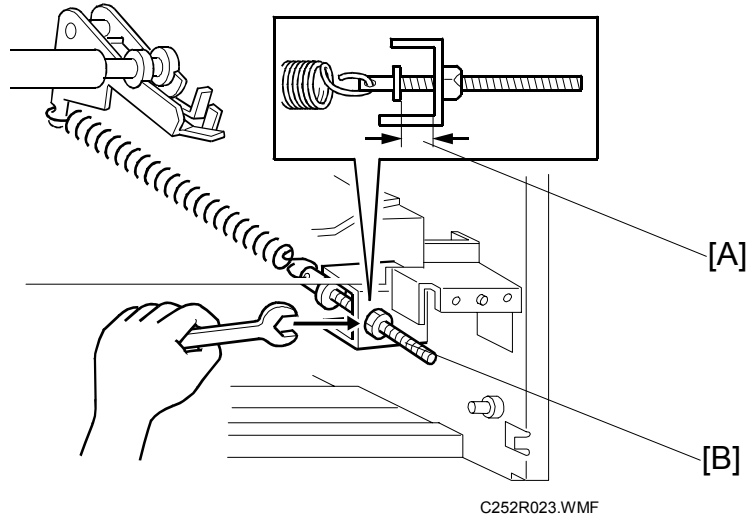

Replacement
Adjustment

- Paper delivery unit (☛ 3.10.1)
 1. Adjust the distance [A] to 10 ± 0.5 mm by turning the adjusting bolt [B].
 2. Repeat the same procedure for the printing pressure spring at the non-operation side.

3.9 DRUM

3.9.1 PREPARATION

Before attempting any of the procedures in this section, wipe off the ink around the ink roller. To do this, set SP3-6 (ink detection) to off, and feed paper until ink ends. The setting value returns to the default value when power is switched off/on.

3.9.2 CLOTH SCREEN

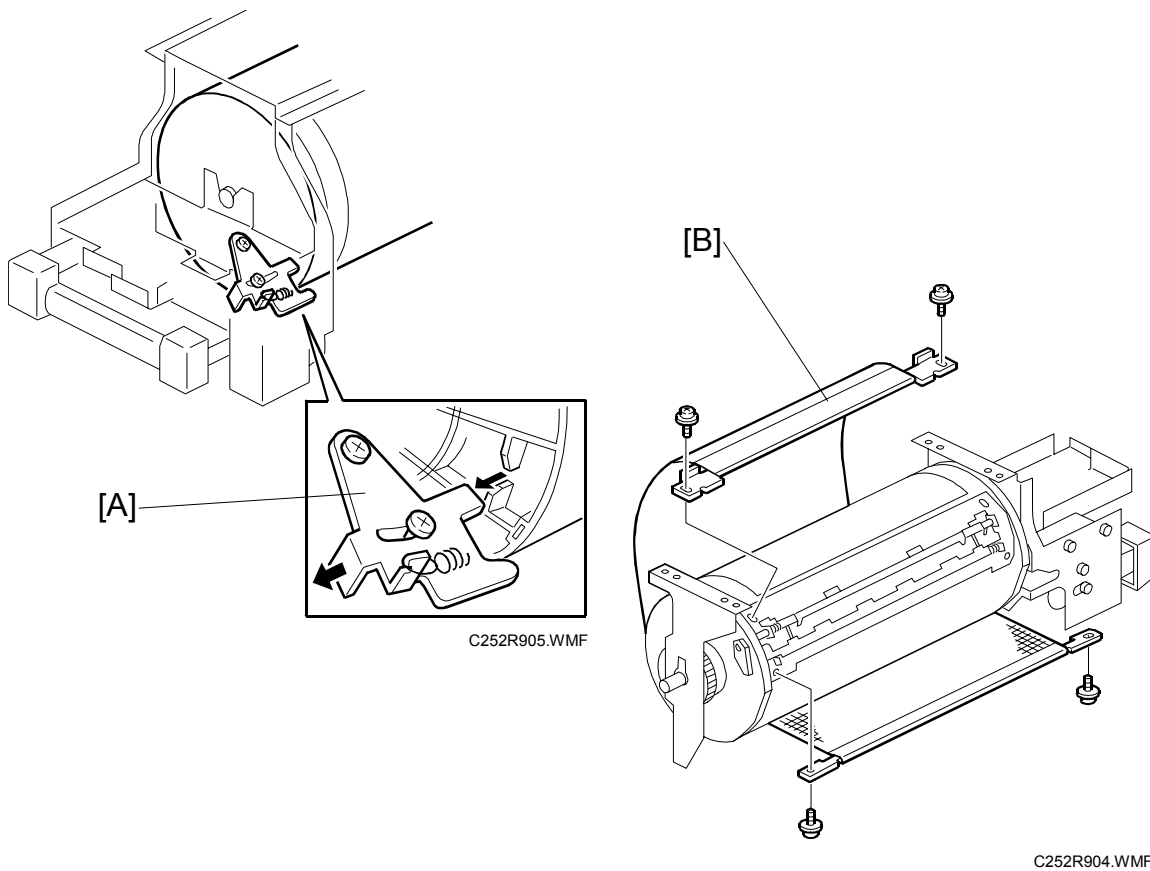

- Remove the drum
 1. Remove the drum upper bracket (⚙ x 4).
 2. Release the stopper [A], then rotate the drum until the master clamber faces top.
 3. Remove the cloth screen [B] (⚙ x 4).

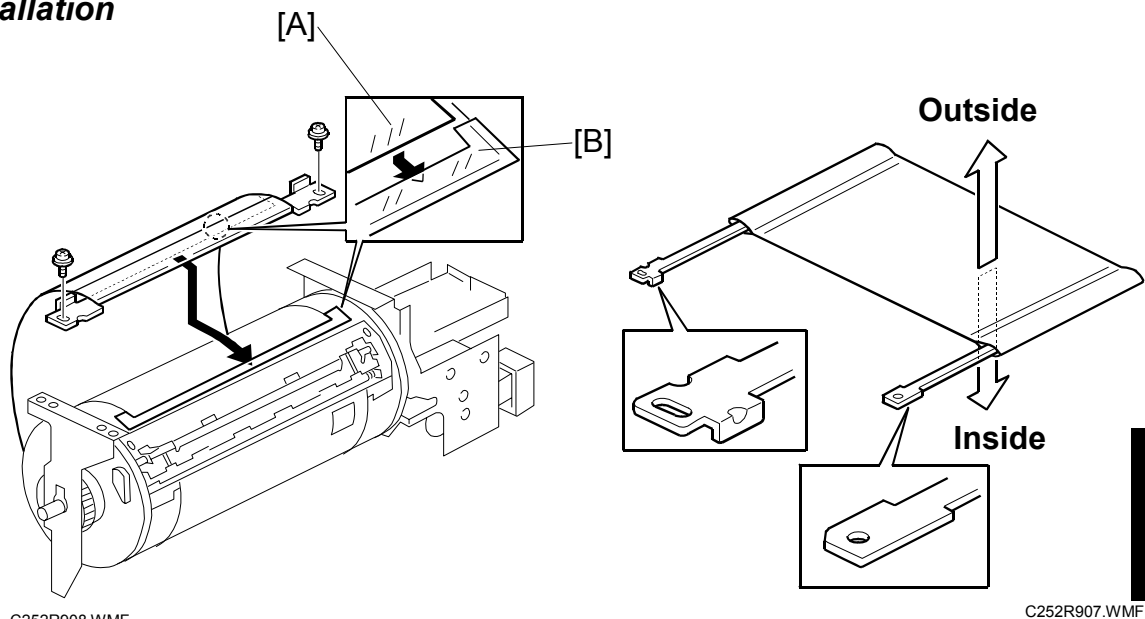
Installation

C252R908.WMF

C252R907.WMF

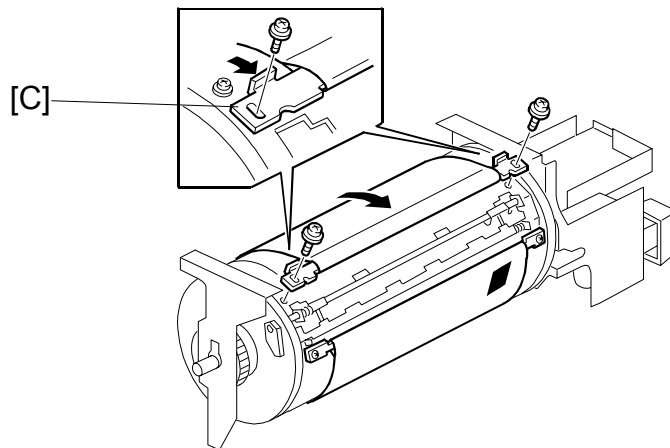
**Replacement
Adjustment**

C252R906.WMF

- Do not scratch the cloth screen or metal screen.
- Properly insert the edge of the mylar [A] on the cloth screen under the mylar [B] on the metal screen, as shown above. Otherwise, ink will leak from the trailing edge of the master on the drum during a long printing run.
- Make sure that the correct side of the screen is facing up. In addition, make sure that the stays for securing the cloth screen are positioned correctly. (Refer to the upper right illustration.)
- When replacing the cloth screen, spread the screen around the metal screen while strongly pulling the stay [C]. Adjust the stay so that it is parallel to the master clasper, then tighten the screws.
- Make sure that the cloth screen is not wrinkled while spreading it around the drum.

3.9.3 CLAMPER / METAL SCREEN

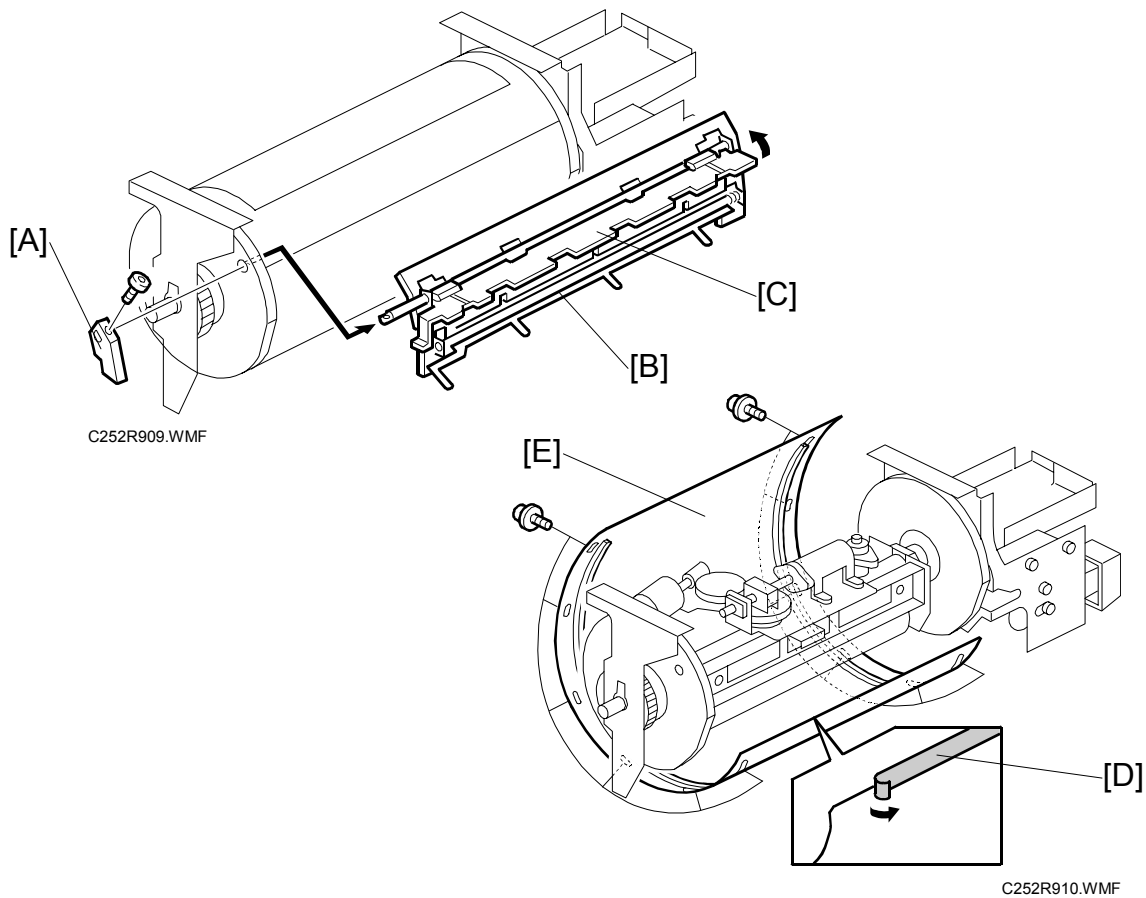

- Remove the drum
- Cloth screen (☛ 3.9.2)

[A]: Clamber lever (1 hexagon screw)

[B]: Clamber - open the clamping plate [C], then remove the clamber.

- NOTE:** 1) Do not allow ink to get on the inside of the clamping plate [C]. Otherwise, the master may slip off and the image position on the prints will move toward the trailing edge of the prints during a printing run.
- 2) Use a cloth dampened with water to clean the inside of the clamping plate [C]. Never use alcohol or other solvents, or the clamping force of the magnet will be weakened.

[D]: Tape (do not lose it)

[E]: Metal screen (☛ x 12)

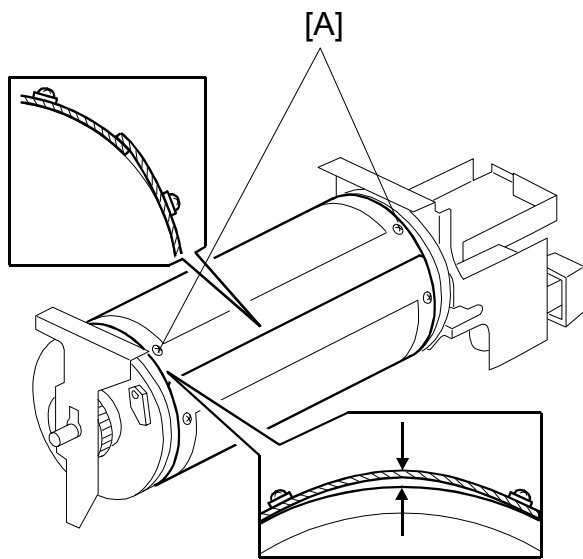
Installation

C252R911.WMF

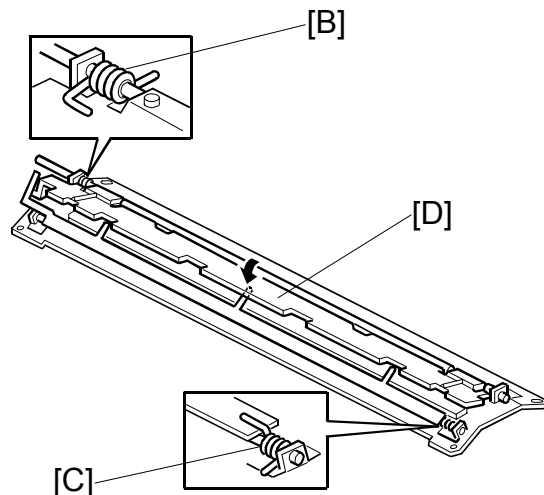

C252R912.WMF

- Make sure that the correct end of the metal screen is overlapping. (The right side overlaps, as viewed from the non-operation side, as shown above.)
- The 4 screws holding the drum master clamber are longer than the 12 screws holding the metal screen, although they are similar in appearance. Be careful not to mix them up or use the wrong screws.
- When installing the metal screen, secure the trailing edge first with the 2 screws. Then, tighten the other screws while removing the slack from the screen. Make sure that the gap between the drum flanges and the screen is 0.3 mm or less, as shown above. (The two holes [A] on the trailing side are round holes and the other holes are long holes, to allow for the removal of the slack.)
- Position the springs [B] and [C] (one each at the front and rear) as shown when reinstalling the drum master clamber [D].
- Do not scratch the cloth screen or metal screen.

3.9.4 INK PUMP ADJUSTMENT

Purpose: To ensure the smooth operation of the ink pump plunger by properly positioning its holder.

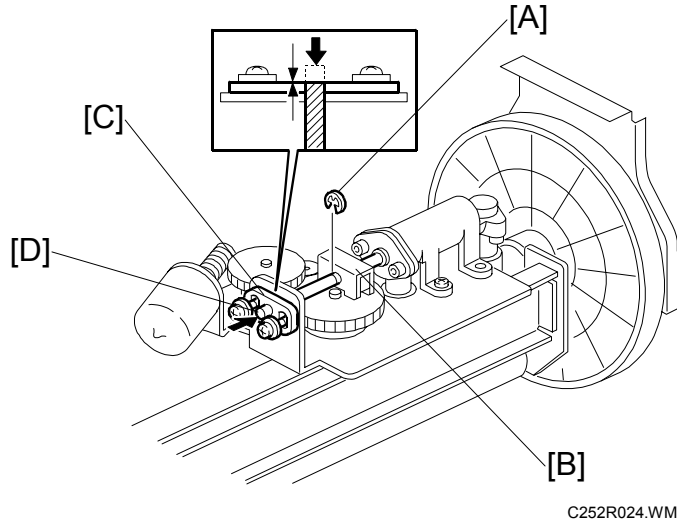

C252R024.WMF

- Remove the drum
 - Cloth screen (☛ 3.9.2)
 - Clamper / Metal screen (☛ 3.9.3)
1. Remove the E-ring [A] to free the plunger from the pump drive slider [B].
 2. Loosen the two screws securing the holder [C]. (Do not remove the holder.)
 3. Push the plunger [D] until it reaches the bottom.

NOTE: The end of the plunger [D] should project 1mm outside from the holder [C].

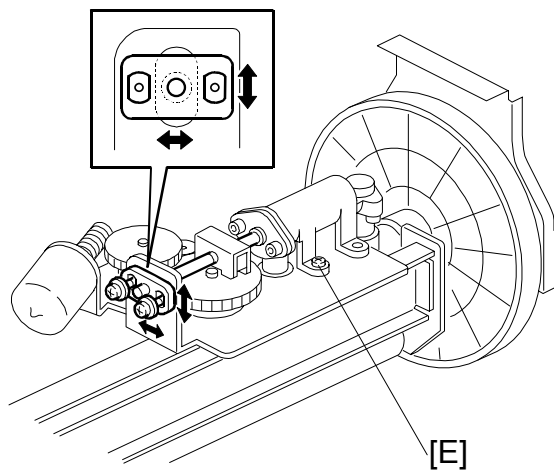

C252R025.WMF

4. Check that the piston motion is smooth.
5. If the motion is stiff, loosen the pump screws [E] and adjust the pump position.
6. After tightening, repeat step 4 and step 5.

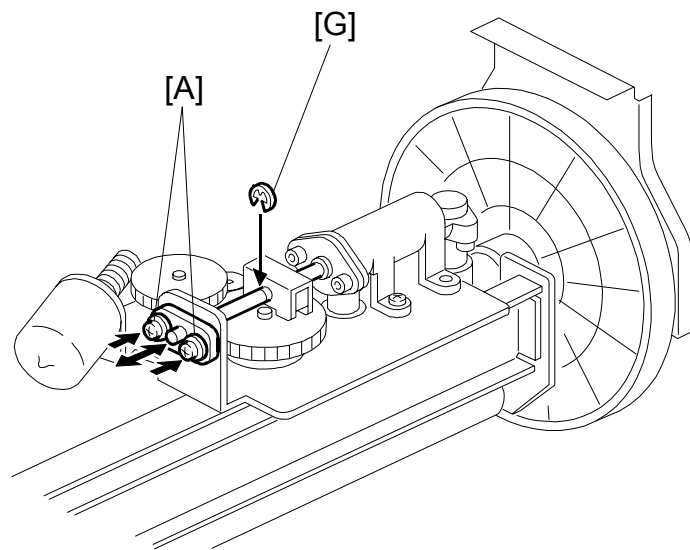

C252R026.WMF

Replacement
Adjustment

7. Re-tighten the two screws [A].
8. Check that the piston motion is smooth.
9. Reinstall the E-ring [B].

3.9.5 DOCTOR ROLLER GAP ADJUSTMENT

Purpose: To control the ink thickness around the ink roller.

Standard: A 0.07mm gauge passes, but a 0.09mm gauge does not.

Tools: Thickness gauge

⚠ CAUTION

Normally the doctor roller gap is not adjusted or changed. It tends to be difficult to change in the field. If the gap is too narrow, an uneven image may appear on the prints. If it is too wide, too much ink will be applied to the drum screens, resulting in ink leakage from the drum.

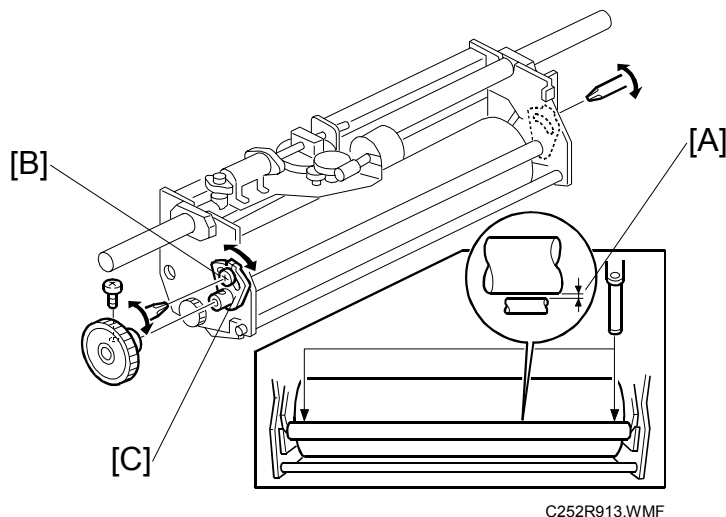

- Wipe off the ink around the ink roller beforehand. (Use SP3-6.)
 - Remove the drum
 - Remove the Ink roller unit
1. Make sure that a 0.07 mm gap gauge goes through the gap [A] between the ink and doctor rollers, and that a 0.09 mm gap gauge does not.

NOTE: 1) The gap should be checked at both ends of the doctor roller. Insert a gap gauge at each end of the roller. The gap tends to be larger for the center.

2) While the gap gauge is inserted, hold the doctor and ink rollers with your fingers in order to stop the rollers from rotating.

3) While the gap gauge is inserted, hold the end of the gap gauge.
 2. If the gap is out of the standard, loosen the screw [B] and adjust the gap by turning the cam bushing [C] for the front and for the rear.

NOTE: Make sure to repeat the adjustment for both ends of the rollers.

3.9.6 INK DETECTION ADJUSTMENT

Purpose: To ensure that the CPU detects a no ink condition.

CAUTION: Before attempting this procedure, wipe off the ink around the ink roller. To do this, set SP3-6 (Ink Detection) to OFF, and feed paper until ink ends. The setting value returns to default value if the power is switched off/on.

Standard: $4.0 \pm 0.2\mu\text{s}$

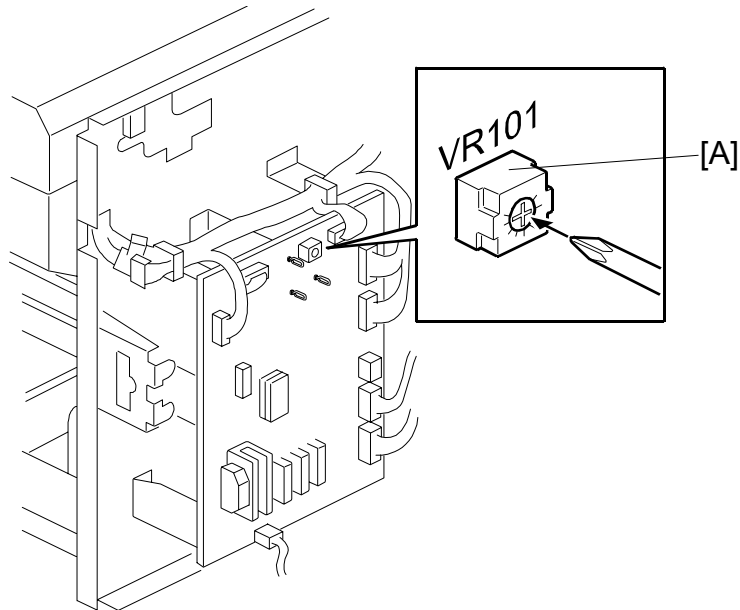

C252R037.WMF

- Rear cover (☛3.2.2)

1. Access SP6-40.
2. Turn VR101 [A] on the MPU board until the display is " $4.0 \pm 0.2\mu$ " ($4.0 \pm 0.2\mu\text{s}$).

NOTE: When the drum has ink inside, the machine displays "----".

3.10 PAPER DELIVERY

3.10.1 PAPER DELIVERY UNIT

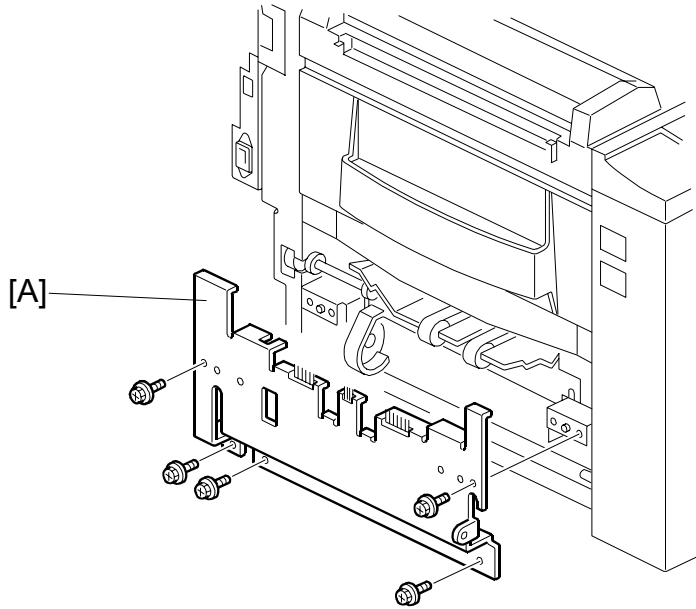

C252R027.WMF

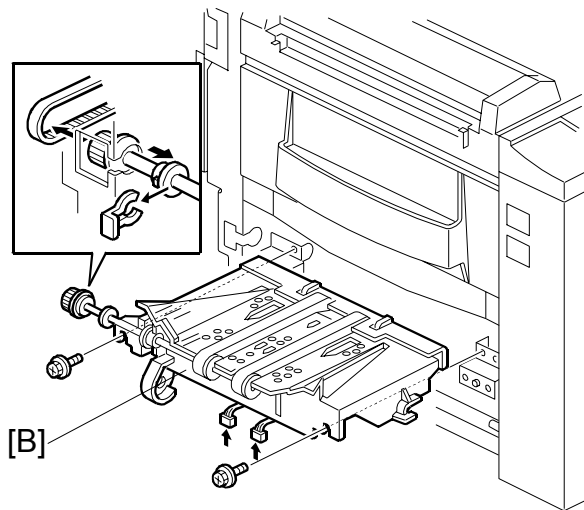

C252R028.WMF

- Rear cover (☛3.2.2)
- [A]: Paper delivery cover (🔩 x 5)
- [B]: Paper delivery unit (🔩 x 2, 🛠 x 2, 🛠 x 1)

3.10.2 DELIVERY BELT / PAPER EXIT SENSOR

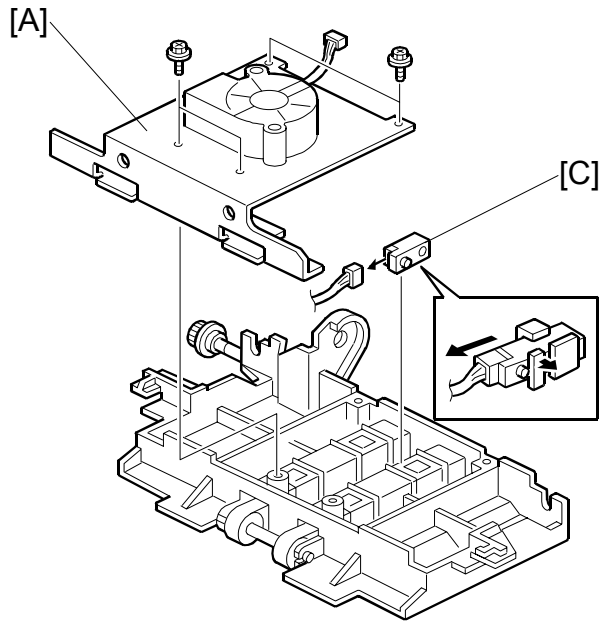

C252R029.WMF

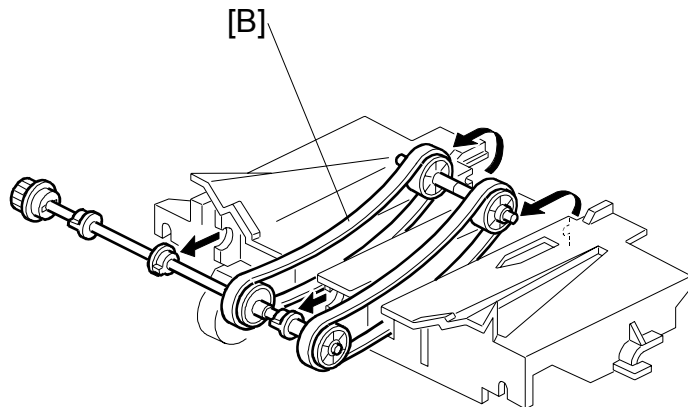

C252R030.WMF

- Remove paper delivery unit (☛ 3.10.1)
- [A]: Vacuum fan motor bracket (🔩 x 4)
- [B]: Delivery belts
- [C]: Paper exit sensor (🔌 x 1)

Replacement
Adjustment

3.10.3 VACUUM FAN MOTOR POSITION

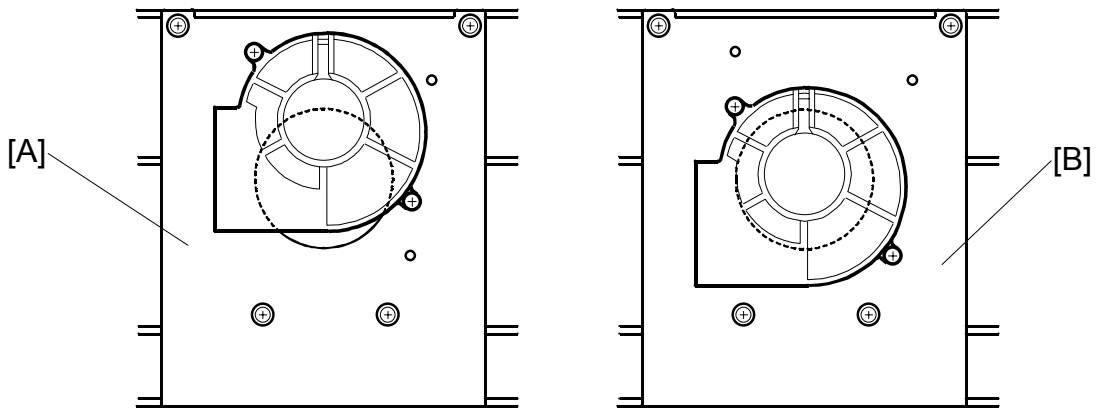

C252R031.WMF

- Remove the paper delivery unit (☛ 3.10.1)
- [A]: For the China model
[B]: For other models

3.10.4 EXIT PAWL ADJUSTMENT

Purpose: To ensure that the exit pawls can move out of the way of the drum master clamber while the drum is rotating.

Clearance adjustment

Standard: Within 1.15 ± 0.15 mm

- Front cover (☛3.2.1), Rear cover (☛3.2.2)

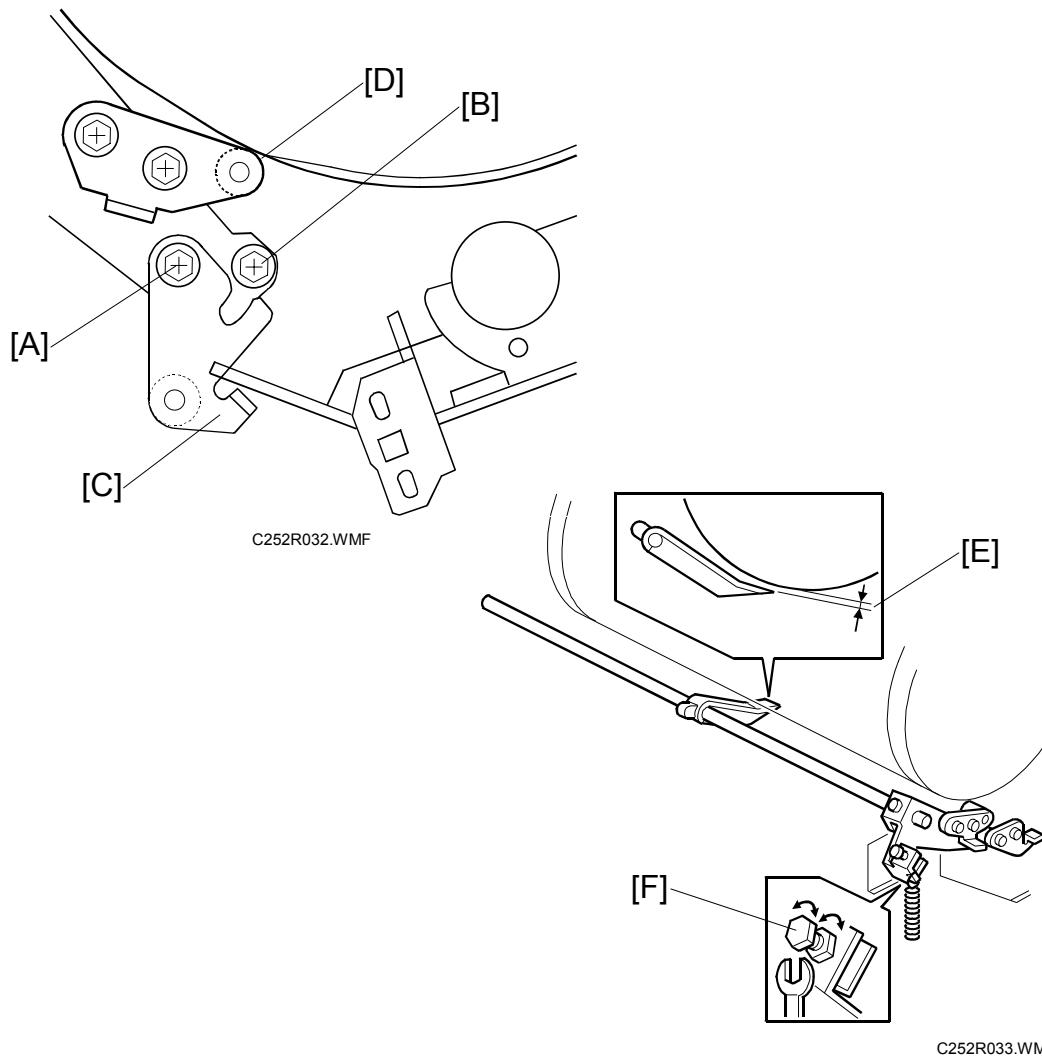

Replacement
Adjustment

1. Loosen screw [A] then screw [B] in this order (do not remove them). Make sure that the bracket [C] becomes free from engagement and the cam follower [D] contacts the drum flange.
2. Using a gap gauge, measure the clearance [E] between the drum surface and the exit pawls. It should be 1.15 ± 0.15 mm.
3. If the clearance is not correct, adjust the clearance by turning the bolt [F].
4. Reposition the bracket [C] and tighten the screws [A] and [B].
5. Do the timing adjustment (see the next section).

Timing adjustment

Standard: 0 or less than 0.5 mm

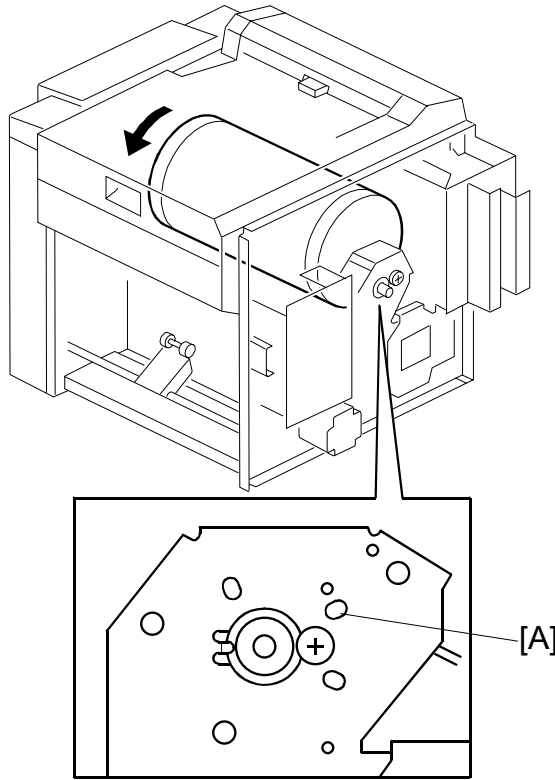

C252R022.WMF

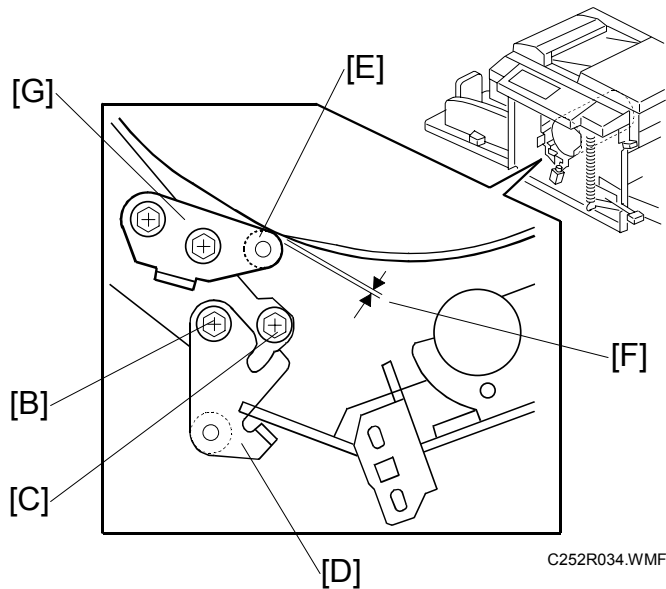

C252R034.WMF

- Front cover (☛ 3.2.1), Rear covers (☛ 3.2.2)

Do this after the clearance adjustment (the procedure is on the next page).

1. Turn the drum manually until the recess in the drum drive gear meets the positioning hole [A] in the bracket, as shown.
2. Loosen screw [B] then screw [C] in that order (do not remove them). Make sure that the bracket [D] becomes free from engagement and the cam follower [E] contacts the drum flange.
3. Measure the gap [F] between the cam follower and cam face (front drum flange). It should be 0 to 0.5 mm.
4. If the gap is not correct, loosen the two screws securing the cam follower bracket [G].
5. Re-tighten the two screws while pushing the cam follower against the cam face. Make sure that the gap [F] is 0 or less than 0.5 mm.
NOTE: Do not push the cam followers too strongly against the cam.
6. Re-position the bracket [D] and tighten the screws [B] and [C].

3.11 MAIN DRIVE

3.11.1 MAIN DRIVE TIMING BELT ADJUSTMENT

After the timing belt is replaced, correct belt tension must be applied.

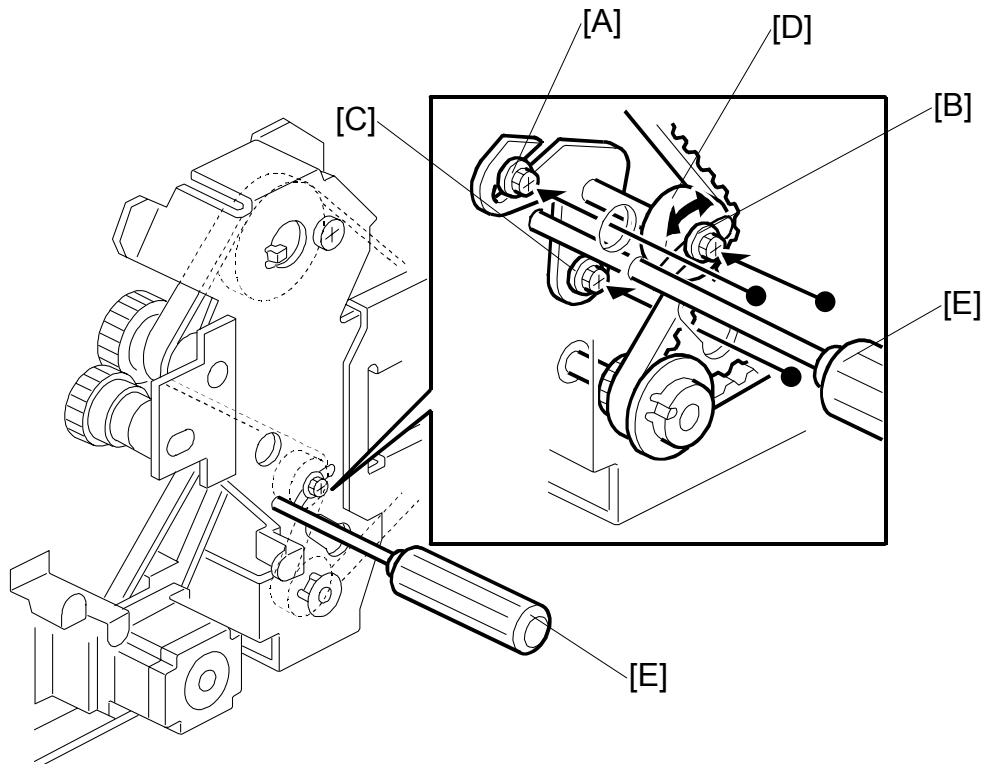

C252R035.WMF

- Rear cover (☛3.2.2)
- MPU (☛3.3.1)
- PSU (☛3.3.2)

1. Loosen the screws [A], [B], and [C].
2. Move the tension roller [D] to the right with a screwdriver [E] as shown.
3. Tighten the screws [A], [B], and [C].
4. Remove the screwdriver.

3.11.2 MAIM MOTOR PULLEY POSITION

After putting the pulley back on the main motor shaft, refer to the above illustration for the correct position of the pulley.

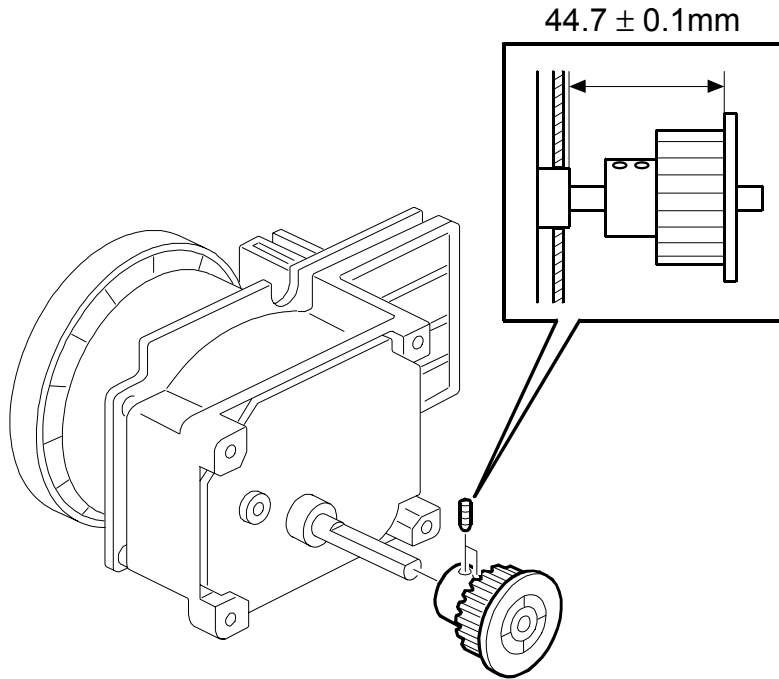

Replacement
Adjustment

C252R036.WMF

3.12 FIRMWARE UPDATE

The firmware in the EPROM on the MPU can be upgraded replacing the EPROM.

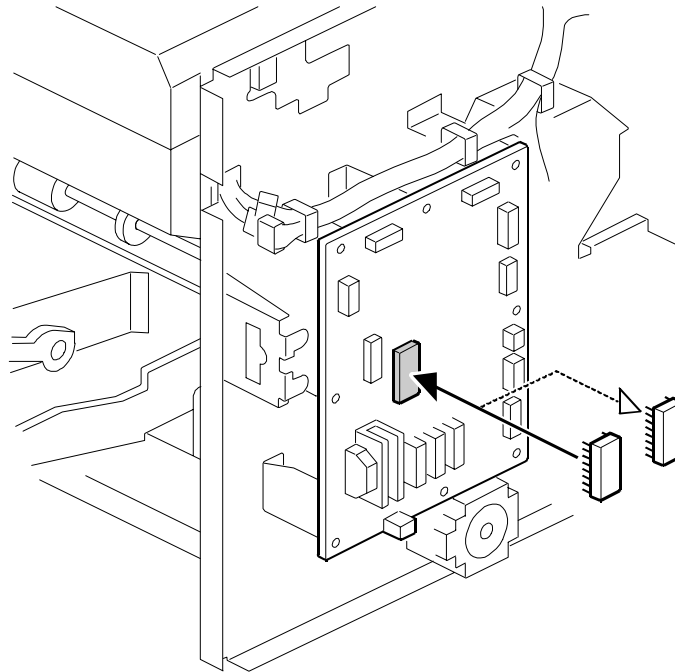

C252R040.WMF

1. Before upgrading the firmware, check the current suffix version with SP3-1.
2. Turn off the main switch and disconnect the power plug.
3. Remove the rear cover.
4. Replace the EPROM on the MPU.
5. Connect the power plug and turn on the main switch.
6. Access SP3-1 and confirm that the suffix version was changed.

4. TROUBLESHOOTING

4.1 ERROR CODES

No.	Symptom	Possible cause
E-00	<u>Clamper error</u> The MPU cannot detect the clamper position sensor signal (open or closed) within 3.0 seconds after the clamper motor turns on.	Clamper drive Clamper sensors Clamper motor
E-01	<u>Cutter error</u> The cutter HP sensor does not turn on within 3.0 seconds after the cutter motor turns on.	Cutter drive Cutter switch Cutter motor
E-03	<u>Thermal Head ID Error</u> The CPU detects an abnormal ID signal from the thermal head.	Thermal head MPU
E-04	<u>Thermal Head Overheat</u> The temperature of the thermal head is greater than 54°C when the Start key is pressed.	Overheat (wait for the thermal head to cool down) Thermal head
E-06	<u>Main Motor error</u> The CPU cannot detect the master eject position sensor (drum HP) signal within 2.5 seconds after the main motor turns on.	Main motor drive Main motor Motor drive board Master eject position SN
E-09	<u>Thermal Head Thermistor Open</u> The thermistor output voltage is over 4.9 volts.	Thermal head thermistor Thermal head connector
E-10	<u>Thermal Head Drive Failure</u> The CPU detects an abnormal condition in the thermal head drive circuit.	Thermal head MPU Thermal head connector
E-12	<u>Pressure Plate error</u> The pressure plate home position sensor signal is not detected within 3.0 seconds after the pressure plate motor turns on.	Pressure plate drive Pressure plate motor Plate position sensors
E-14	<u>IPU error</u> Signal transmission error (from the IPU) occurred in the MPU	MPU
E-23	<u>Master Eject Position Sensor (Drum HP) error</u> The master eject position sensor does not activate before the feed start timing sensor activates.	Master eject position sensor Feed start timing sensor Feeler
E-24	<u>Feed Start Timing Sensor error</u> The feed start timing sensor does not activate before the master eject sensor activates.	Master eject position sensor Feed start timing sensor Feeler

4.2 ELECTRICAL COMPONENT DEFECTS

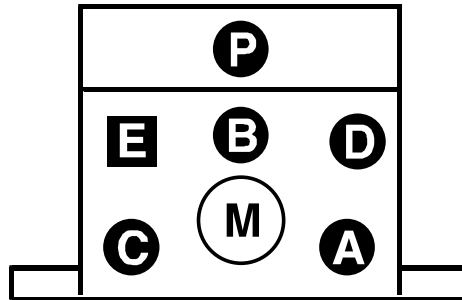

C252T900.WMF

Component	Condition	Symptom
Original Sensor	Open	The P jam indicator is lit whenever the main switch is on.
	Shorted	The P jam indicator is lit whenever a master is made.
Master Eject Sensor	Open	The E jam indicator is lit whenever the main switch is on.
	Shorted	The E jam indicator is lit whenever a used master is ejected.
Pressure Plate HP Sensor	Open	E-12 is displayed whenever the main switch is on.
	Shorted	
Pressure Plate Limit Sensor	Open	E-12 is displayed whenever the main switch is on.
	Shorted	The master eject indicator is lit whenever the main switch is on.
Feed Start Timing Sensor	Open	E-6 is displayed whenever the main switch is on.
	Shorted	E-24 is displayed whenever the main switch is on.
Master Eject Position (Drum HP) Sensor	Open	E-6 is displayed whenever the main switch is on.
	Shorted	E-23 is displayed whenever the main switch is on.
Drum Master Sensor	Open	The D jam indicator is lit whenever a proof print is made.
	Shorted	The D jam indicator is lit whenever a master is made. The M indicator is lit whenever a copy is made.
Paper Exit Sensor	Open	The C jam indicator is lit whenever the main switch is on.
	Shorted	The B jam indicator is lit whenever a copy is made.

Component	Condition	Symptom
Clamper Open Sensor	Open	E-00 is displayed whenever the clamper operates.
	Shorted	
Clamper Closed Sensor	Open	E-00 is displayed whenever the clamper operates.
	Shorted	E-00 is displayed whenever the main switch is on.
Master End Sensor	Open	Master making can start even if there is no master roll, but the D jam indicator will be lit.
	Shorted	The master end indicator is lit.
Right Side Cover Set Switch	Open	The open cover indicator is lit.
	Shorted	The master is made normally, even if the right side cover is open.
Master Set Cover Sensor	Open	The D jam indicator is lit whenever the cover is not placed correctly.
	Shorted	The D and open cover indicator are lit.
Drum Set Connector	Open	E-06 is displayed whenever a master is made.
	Shorted	The M and open cover indicators are lit.
Eject Box Set Sensor	Open	The master is fed to the eject box, even if there is no eject box.
	Shorted	The E and open cover indicators are lit.
Cutter HP Sensor	Open	E-01 is displayed whenever a master is made.
	Shorted	E-01 is displayed whenever the main switch is on.

4.3 FUSE, LED, VR, DIP-SW, AND TP TABLES

4.3.1 BLOWN FUSE CONDITIONS

Main Board

No.	Rate	Possible cause
FU101	1 A	Ink pump motor

PSU

No.	Rate	Possible cause
FU700	6.3 A	AC Line
FU701	6.3 A	Main motor Main motor control board
FU702	6.3 A	Paper feed clutch Air knife fan motor Front/Rear pressure release solenoid Vacuum fan motor Ink pump motor Master eject motor Master/Paper counter Contact Image Sensor (CIS) Pressure plate motor Scanner motor Clamper motor Master feed motor

4.3.2 LED'S

Main Board

No.	Function
LED103	OFF: Low ink condition ON: Sufficient ink condition

4.3.3 VR'S

Main Board

No.	Function
VR101	Adjust the ink detection. (☛3.9.6)
VR102	Adjust the master end sensor. (☛3.5.4)

PSU

No.	Function
VR1	Adjust the thermal head voltage. (☛3.5.3)

4.3.4 TEST POINTS

Main Board

No.	Function
TP101	GND
TP103	Measures the ink detection pulse
TP104	Measures the ink detection pulse (standard pulse)
TP113	GND

PSU

No.	Function
TP701	Thermal head voltage
TP702	GND

4.3.5 DIP SWITCHES

Main Board

DIPSW No.	Bit No.	Name	Settings
101	1 to 4	Paper Registration Position Adjust	☛5.2.2
	5 to 8	Master Writing Position Adjust	☛5.2.3
102	1 to 3	Thermal Head Energy Control	☛5.2.4
	4	Not used	-
	5	Drum Size Selection	ON: LG OFF: B4
	6	Size in Metric or Inch	ON: inch OFF: mm
	7	Panel Beeper	ON: Enabled OFF: Disabled
103	8	Not used	-
	1 to 4	Scanning Speed Adjustment	☛5.2.5
	5 to 8	Master Feeding Speed Adjustment	☛5.2.6

4.4 JAM DETECTION

4.4.1 MASTER EJECT JAM (E JAM LOCATION INDICATOR)

Picking up the used master from the drum

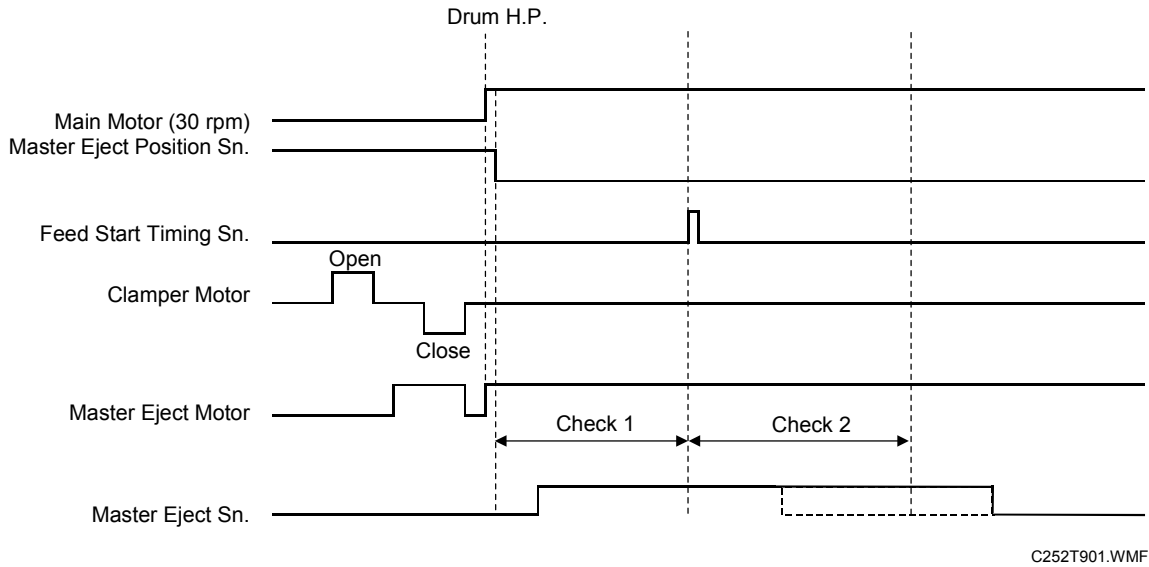

Check 1:

When the drum has rotated, if the master eject sensor doesn't detect the master, the E jam indicator lights.

Check 2:

When the feed start timing sensor turns on, if the master eject sensor has already turned off, the E jam indicator lights.

Compressing the used master

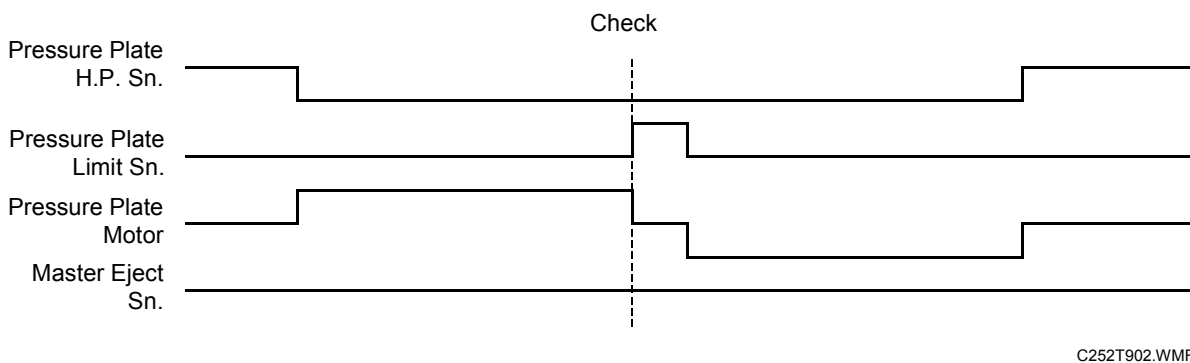

Check:

If the master eject sensor detects a master when the pressure plate limit sensor turns on, the E jam indicator lights.

Just after turning on the main switch***Check:***

If the master eject sensor is on (master detected), the E jam indicator lights.

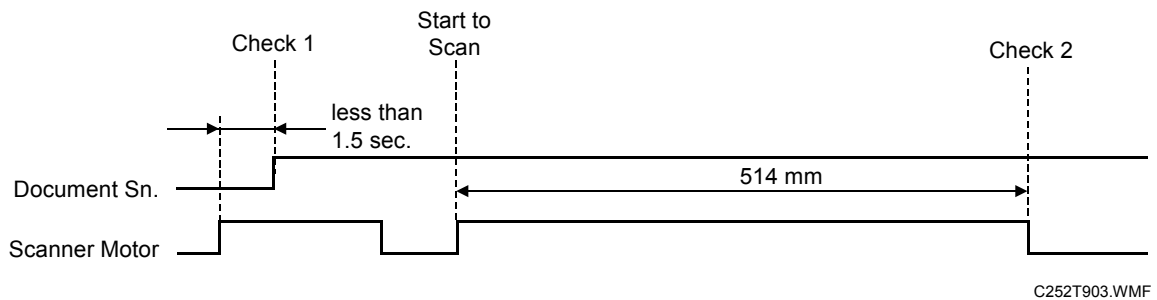
4.4.2 SCANNER JAM (P JAM LOCATION INDICATOR)***Feeding in the original******Check:***

If the document sensor detects an original when the master making key was pressed, the P jam indicator lights.

Check 1:

If the scanner has fed the original for 1.5 seconds since the master making key was pressed, and the document sensor still doesn't detect the original, the P jam indicator lights.

Feeding out the original***Check 2:***

When the scanner has fed out the correct length, but the document sensor still detects the original, the P jam indicator lights.

Just after turning on the main switch***Check:***

If the document sensor detects an original, the P jam indicator lights.

4.4.3 MASTER FEED JAM (D JAM LOCATION INDICATOR)

Cutting the master (master not cut)

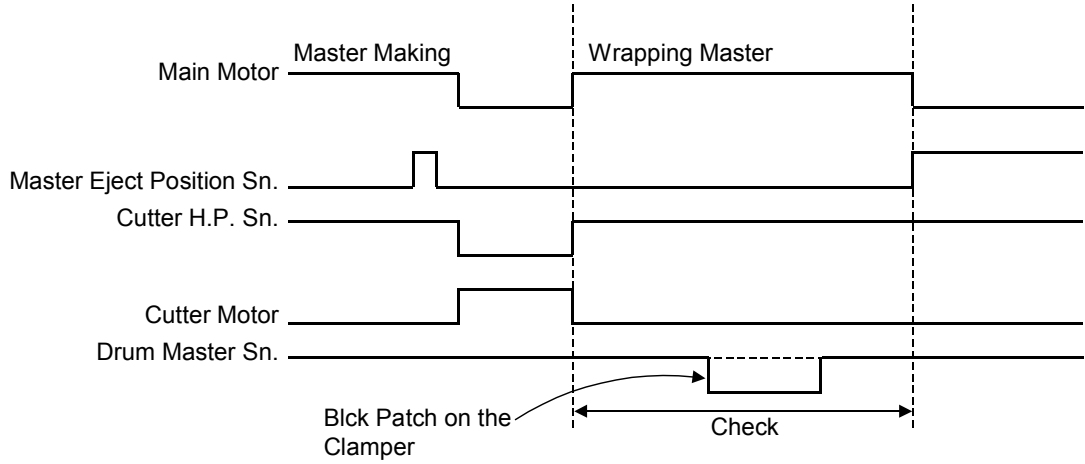

C252T904.WMF

Check:

While the drum is rotating from when the cutter home position sensor turns on (cutter at home position) until the master eject position sensor turns on (drum at master eject position), if the drum master sensor doesn't detect a master on the black patch on the drum clamper, then the D jam indicator lights.

Cutting the master (cutter unit problem)

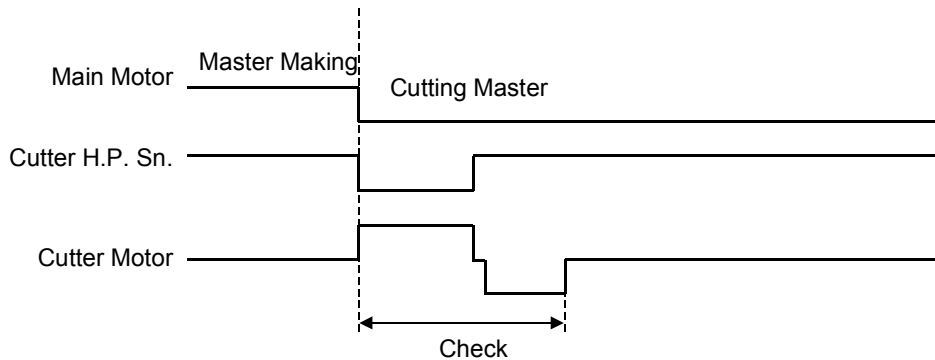

C252T905.WMF

Check:

During master cutting, if the cutter HP sensor does not turn on (the cutter does not reach home position) at the desired time, then the D jam indicator lights.

Clamping the master

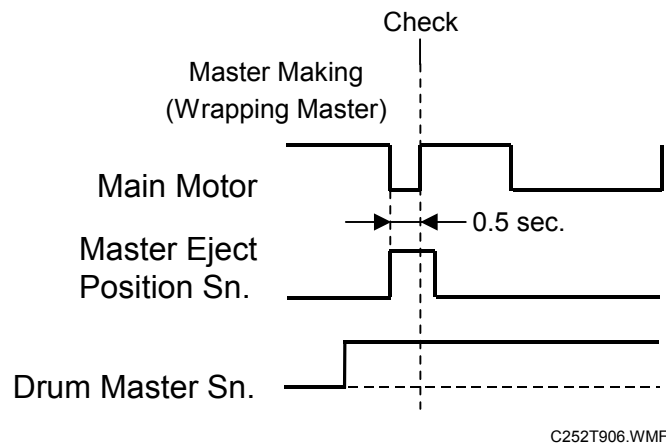

Check:

When the master eject position sensor turns on (drum at master eject position) after 0.5 second, if the drum master sensor doesn't detect a master, then the D jam indicator lights.

Trouble-shooting

4.4.4 DRUM JAM (B JAM LOCATION INDICATOR)

Wrapping jam

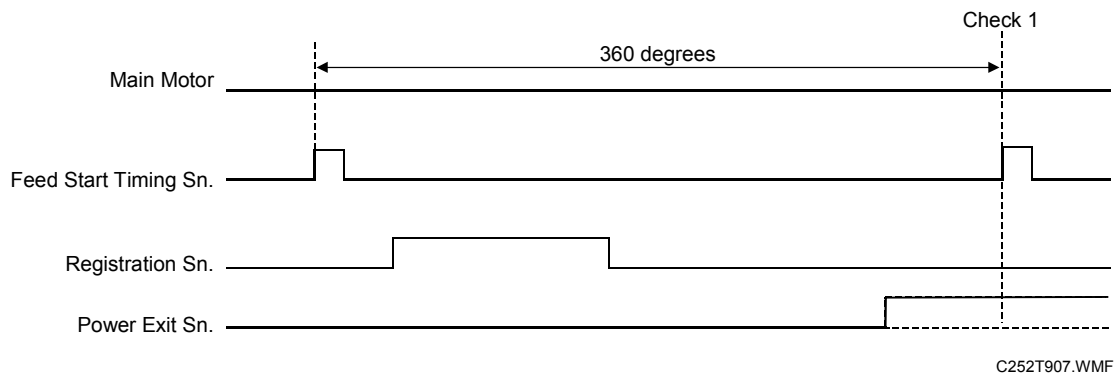

Check 1:

When the drum has turned 360 degrees since the feed start timing sensor turned on, and the paper exit sensor still doesn't detect the paper, then the B jam indicator lights.

Check:

At the same time as check 1, if the paper exit sensor doesn't detect the paper and the registration sensor is on, then the A and B jam indicators light.

4.4.5 PAPER FEED JAM (A JAM LOCATION INDICATOR + 📄 + 📄)

Paper feed

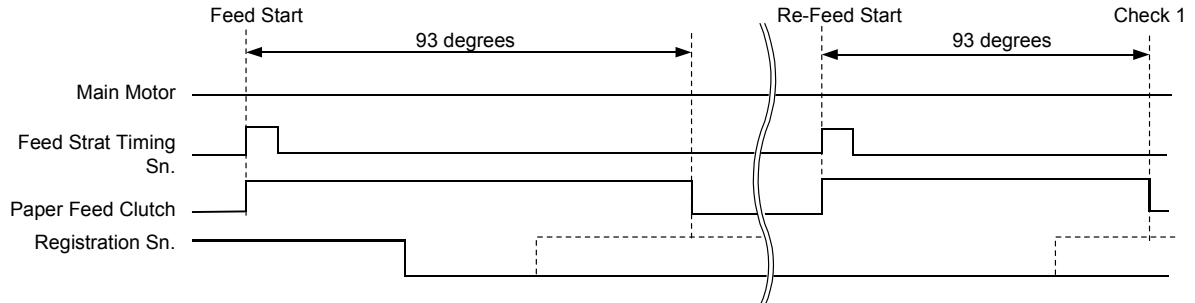

C252T908.WMF

Check 1:

If the registration sensor does not detect paper after the drum has turned 93 degrees, the feed clutch stops until the drum reaches the feed start position again, then the feed clutch turns on again (this is 're-feeding'). If the registration sensor still doesn't detect paper after the drum has turned 93 degrees since re-feeding started, the A jam location, 📄, and 📄 indicators light.

Note that the machine also follows this pattern if the tray is empty. There is no paper end sensor; the registration sensor is used to detect paper end.

Just after turning on the main switch

Check:

If the registration sensor detects paper, the A and B jam location indicators light.

4.4.6 PAPER DELIVERY JAM (C JAM LOCATION INDICATOR)

Paper delivery

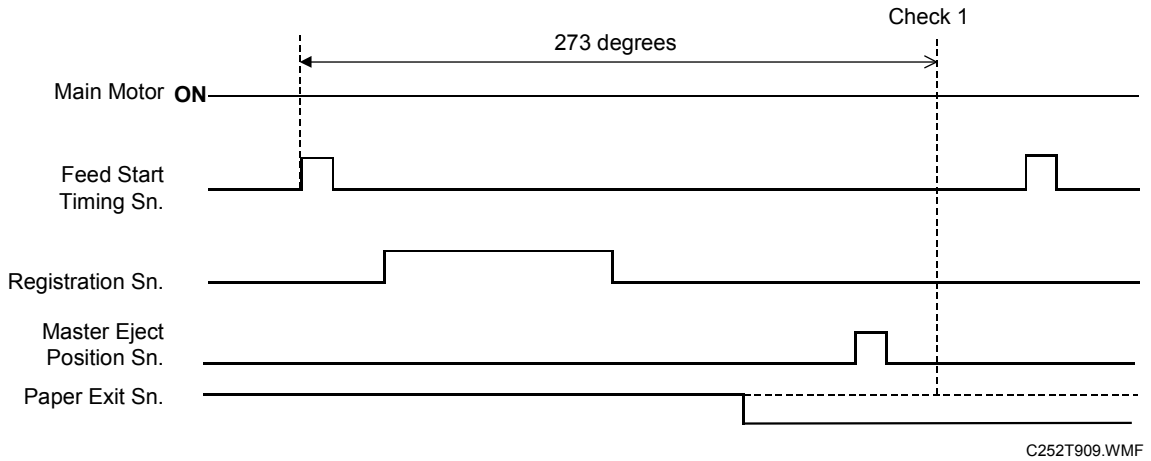

Check 1:

When the drum has turned 273 degrees since the feed start timing sensor turns on, if the paper exit sensor detects paper, the C jam location indicator lights.

Just after turning on the main switch

Check:

If the paper exit sensor detects paper, the C jam location indicator lights.

Trouble-shooting

5. SERVICE TABLES

NOTE: The Service Program Mode is for use by service representatives only so that they can properly maintain product quality. If this mode is used by anyone other than service representatives for any reason, data might be deleted or settings might be changed. In such case, product quality cannot be guaranteed any more.

5.1 SERVICE PROGRAM MODE

The service program (SP) mode is used to check electrical data, change modes.

5.1.1 SERVICE PROGRAM MODE OPERATION

To Enter and Exit the SP Mode

1. Key in the following sequence.

Method 1:

☒ → ① → ⑦ → ⑦ → C/Ⓜ

Hold down Clear/Stop C/Ⓜ for more than three seconds.

Method 2:

☒ → C/Ⓜ → Combine Key → #

2. The SP number is displayed. (e.g. SP1)
3. To exit SP mode, press Clear Modes/Recovery ☒.

Using the SP mode

SP command numbers can be entered directly.

1. Using the number keys, enter the desired main-menu number, then press the Enter key.
2. Using the number keys, enter the desired sub-menu number, then press the Enter key.
3. Enter the desired value using the number keys.
4. Press the enter key to store the displayed setting.

5.1.2 MAIN MENU NO.1: INPUT MODE

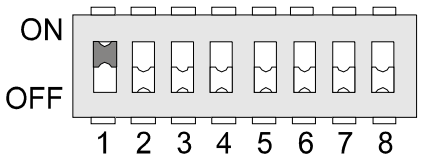
No.	Name	Note
1-3	Original Sensor	
1-26	Master End Sensor	
1-27	Ink Detection Signal	
1-31	Pressure Plate Home Position Sensor	
1-32	Pressure Plate Limit Position Sensor	
1-33	Master Eject Box Set Sensor	
1-42	Paper Exit Sensor	
1-43	Master Eject Sensor	
1-44	Drum Master Sensor	
1-52	Door Safety Switch Master Making Unit Set Sensor	
1-53	Cutter Home Position Sensor	
1-56	Feed Start Timing Sensor	
1-59	Master Eject Position Sensor	
1-62	Drum Set Signal	
1-65	Clamper Close Sensor	
1-66	Clamper Open Sensor	
1-68	Paper Registration Sensor	
1-70	Master Set Cover Sensor	
1-71	DIPSW 103-1	Use these SPs to test whether the DIP switches are working properly. 
1-72	DIPSW 103-2	
1-73	DIPSW 103-3	
1-74	DIPSW 103-4	
1-75	DIPSW 103-5	
1-76	DIPSW 103-6	
1-77	DIPSW 103-7	
1-78	DIPSW 103-8	
1-79	DIPSW 101-1	
1-80	DIPSW 101-2	
1-81	DIPSW 101-3	
1-82	DIPSW 101-4	
1-83	DIPSW 101-5	
1-84	DIPSW 101-6	
1-85	DIPSW 101-7	
1-86	DIPSW 101-8	
1-87	DIPSW 102-1	
1-88	DIPSW 102-2	
1-89	DIPSW 102-3	
1-90	DIPSW 102-4	
1-91	DIPSW 102-5	
1-92	DIPSW 102-6	
1-93	DIPSW 102-7	
1-94	DIPSW 102-8	

C252S901.WMFF

5.1.3 MAIN MENU NO.2: OUTPUT MODE

No.	Name	Note
2-3	Master Eject Motor	Press and hold the master making key to start the test. Release the key to stop the test.
2-6	Vacuum Fan Motor	
2-7	Air Knife Fan Motor	
2-9	Master Counter	
2-10	Paper Counter	
2-12	Ink Pump Motor	
2-14	Pressure Release Solenoids	
2-21	Exposure Lamp (Xenon Lamp)	
2-22	Cutter Motor: + direction	
2-23	Cutter Motor: to Home	
2-24	Cutter Motor: - direction	
2-27	Main Motor: to drum home position	
2-28	Main Motor: to master making position	
2-36	Master Feed Motor	
2-37	Scanner Motor	
2-41	Thermal Head Signal Output (VHD Signal) ●5.1.4	
2-42	Paper Feed Clutch	
2-44	Clamper Motor: to close	
2-45	Clamper Motor: to open	
2-46	Pressure Plate Motor: to limit	
2-47	Pressure Plate Motor: to home position	
2-48	Main Motor: 30rpm	
2-49	Main Motor: 60rpm	
2-50	Main Motor: 90rpm	
2-51	Paper Feed Motor: 30rpm	
2-52	Paper Feed Motor: 60rpm	
2-53	Paper Feed Motor: 90rpm	

5.1.4 SP2-41: THERMAL HEAD SIGNAL OUTPUT (VHD SIGNAL)

Applies thermal head voltage.

Power is applied by pressing the # key. To protect the thermal head, the voltage supply is automatically stopped after 30 seconds. It is also stopped by pressing the clear/stop key.

●3.5.3

5.1.5 MAIN MENU NO.3: TEST MODE

No.	Name	Function
3-1	Firmware Suffix Information	☛5.1.6
3-4	All Indicators ON	Turns on all the indicators on the operation panel by pressing the master making key.
3-5	Test Pattern Print	Print the thermal head test pattern by pressing the master making key.
3-6	Ink Detection	Specifies whether ink detection is done. 0: OFF 1: ON (Default) The setting value returns to default value in power switch off.

5.1.6 SP3-1: FIRMWARE SUFFIX INFORMATION

This model has no LCD, so the suffix is displayed as shown below instead of in Latin letters.

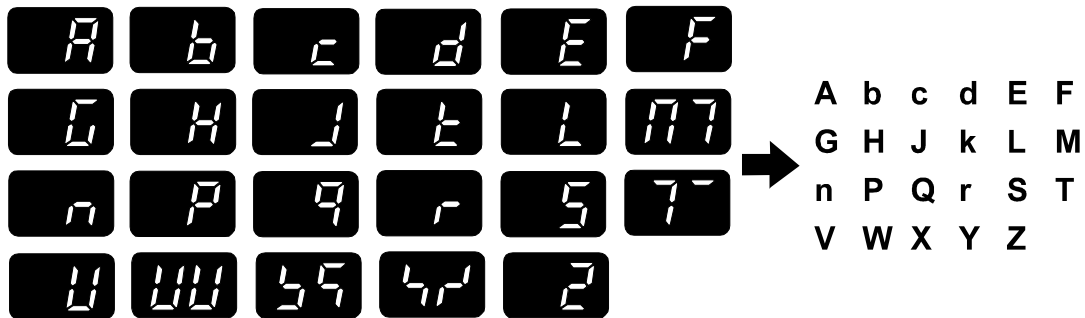

C252S900.WMF

NOTE: The letters “i”, “o” and “u” are always skipped.

5.1.7 MAIN MENU NO.6: ADJUSTMENT MODE

No.	Name	Function
6-40	Ink Detection Adjustment	☛3.9.6
6-41	Master End Sensor Adjustment	☛3.5.4
6-42	Image Adjustment Pattern Print	☛5.1.10

5.1.8 SP6-42: IMAGE ADJUSTMENT PATTERN PRINT

This test pattern is used for master feeding speed adjustment.

- Master Feeding Speed Adjustment: 5.2.6

This test pattern is generated in the MPU, and does not use the scanner unit. So, this pattern can also be used to determine whether an image problem is caused by the scanner or the thermal head.

- If there is an image problem during copying but the test print is OK, the problem could be in the scanner unit.

The print paper should be B4 or LG size when using this test pattern.

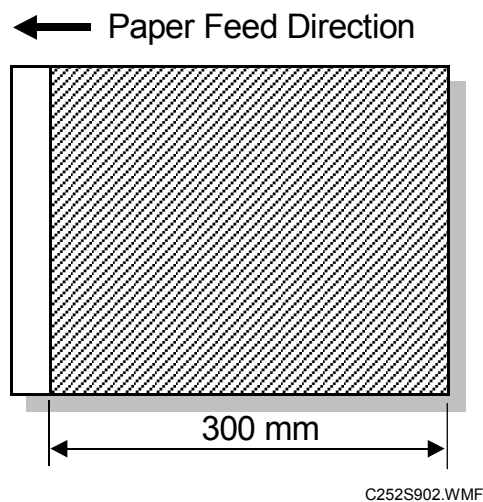

5.2 DIP SWITCHES

5.2.1 OVERVIEW

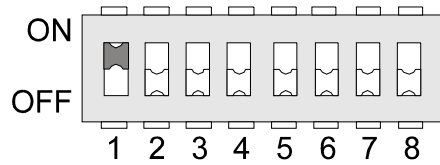

C252S901.WMF

DIPSW No.	Bit No.	Name	Settings
101	1 to 4	Paper Registration Position Adjust	☛5.2.2
	5 to 8	Master Writing Position Adjust	☛5.2.3
102	1 to 3	Thermal Head Energy Control	☛5.2.4
	4	Not used	-
	5	Drum Size Selection	ON: LG OFF: B4
	6	Size in Metric or Inch	ON: inch OFF: mm
	7	Panel Beeper	ON: Enabled OFF: Disabled (Default)
	8	Not used	-
103	1 to 4	Scanning Speed Adjustment	☛5.2.5
	5 to 8	Master Feeding Speed Adjustment	☛5.2.6

5.2.2 DIPSW101 NO.1 TO 4 – PAPER REGISTRATION POSITION ADJUSTMENT

Purpose: To match the printing leading edge on the print paper with that on the original.

Adjustment standard: ± 1.0 mm

The print position moves as shown below.

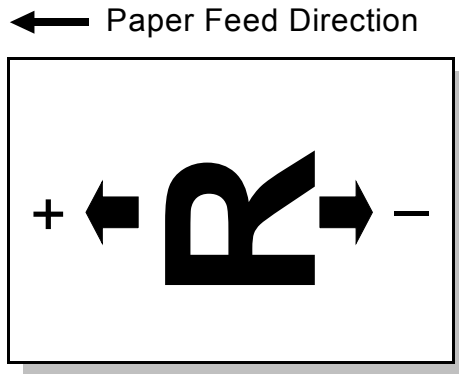

C252S903.WMF

NOTE: The image position on a trial print, which is automatically made after making a master, tends to vary. Do not use the trial print when making adjustments.

Service Tables

DIPSW101-1	DIPSW101-2	DIPSW101-3	DIPSW101-4	Difference	Difference
ON	ON	ON	ON	+7 pulse	+3.563 mm
OFF	ON	ON	ON	+6 pulse	+3.054 mm
ON	OFF	ON	ON	+5 pulse	+2.545 mm
OFF	OFF	ON	ON	+4 pulse	+2.036 mm
ON	ON	OFF	ON	+3 pulse	+1.527 mm
OFF	ON	OFF	ON	+2 pulse	+1.018 mm
ON	OFF	OFF	ON	+1 pulse	+0.509 mm
OFF	OFF	OFF	ON	0	0
OFF	OFF	OFF	OFF	0	0
ON	ON	ON	OFF	-7 pulse	-3.563 mm
OFF	ON	ON	OFF	-6 pulse	-3.054 mm
ON	OFF	ON	OFF	-5 pulse	-2.545 mm
OFF	OFF	ON	OFF	-4 pulse	-2.036 mm
ON	ON	OFF	OFF	-3 pulse	-1.527 mm
OFF	ON	OFF	OFF	-2 pulse	-1.018 mm
ON	OFF	OFF	OFF	-1 pulse	-0.509 mm

1 pulse = 0.509 mm

5.2.3 DIPSW101 NO.5 TO 8 – MASTER WRITING POSITION ADJUSTMENT

Purpose: To match the printing side-to-side on the print paper with that on the original.

Adjustment standard: ± 1.0 mm

The master writing position moves as shown below.

← Paper Feed Direction

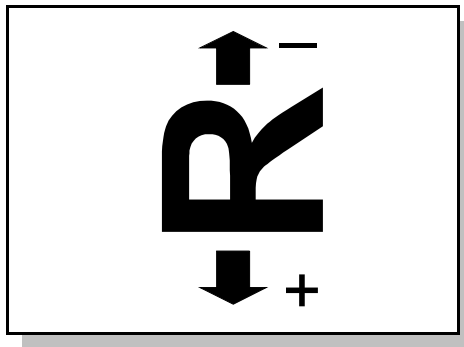

C252S904.WMF

NOTE: The image position on a trial print, which is automatically made after making a master, tends to vary. Do not use the trial print when making adjustments.

DIPSW101-5	DIPSW101-6	DIPSW101-7	DIPSW101-8	Difference	Difference
ON	ON	ON	ON	-28 dots	-2.38 mm
OFF	ON	ON	ON	-24 dots	-2.04 mm
ON	OFF	ON	ON	-20 dots	-1.7 mm
OFF	OFF	ON	ON	-16 dots	-1.36 mm
ON	ON	OFF	ON	-12 dots	-1.02 mm
OFF	ON	OFF	ON	-8 dots	-0.68 mm
ON	OFF	OFF	ON	-4 dots	-0.34 mm
OFF	OFF	OFF	ON	0	0
OFF	OFF	OFF	OFF	0	0
ON	ON	ON	OFF	+28 dots	+2.38 mm
OFF	ON	ON	OFF	+24 dots	+2.04 mm
ON	OFF	ON	OFF	+20 dots	+1.7 mm
OFF	OFF	ON	OFF	+16 dots	+1.36 mm
ON	ON	OFF	OFF	+12 dots	+1.02 mm
OFF	ON	OFF	OFF	+8 dots	+0.68 mm
ON	OFF	OFF	OFF	+4 dots	+0.34 mm

1 dot = 0.085 mm

5.2.4 DIPSW102 NO.1 TO 3 – THERMAL HEAD ENERGY CONTROL

The default is -7%. This means that during printing mode, the thermal head energy is 93 % of the maximum power.

This can help to increase or decrease the image density. However, do not use this SP under normal circumstances.

DIPSW102-1	DIPSW102-2	DIPSW102-3	Settings
OFF	OFF	OFF	-7% (Standard)
OFF	ON	OFF	-5%
OFF	OFF	ON	-3%
OFF	ON	ON	0
ON	OFF	OFF	-10%
ON	ON	OFF	-15%
ON	OFF	ON	-20%
ON	ON	ON	-25%

5.2.5 DIPSW103 NO.1 TO 4 – SCANNING SPEED ADJUSTMENT

Purpose: To adjust the sub-scan magnification for scanning by changing the speed of the scanner motor.

Inputting a positive value stretches the image on the master. Inputting a negative value shrinks it.

Adjustment standard: Within $100 \pm 0.5 \%$

1. Make a copy at 90 cpm (speed “Fast”)
2. Compare the image on the print with that on the original.
3. Make sure that the difference of the sub-scan magnification is within the standard.
4. If it is out of standard, then adjust DIPSW103-1 to 103-4.

NOTE: The image position on a trial print, which is automatically made after making a master, tends to vary. Do not use the trial print when making adjustments.

DIPSW103-1	DIPSW103-2	DIPSW103-3	DIPSW103-4	Difference
ON	ON	ON	ON	+1.4%
OFF	ON	ON	ON	+1.2%
ON	OFF	ON	ON	+1.0%
OFF	OFF	ON	ON	+0.8%
ON	ON	OFF	ON	+0.6%
OFF	ON	OFF	ON	+0.4%
ON	OFF	OFF	ON	+0.2%
OFF	OFF	OFF	ON	0
OFF	OFF	OFF	OFF	0
ON	ON	ON	OFF	-1.4%
OFF	ON	ON	OFF	-1.2%
ON	OFF	ON	OFF	-1.0%
OFF	OFF	ON	OFF	-0.8%
ON	ON	OFF	OFF	-0.6%
OFF	ON	OFF	OFF	-0.4%
ON	OFF	OFF	OFF	-0.2%

5.2.6 DIPSW103 NO.5 TO 8 – MASTER FEEDING SPEED ADJUSTMENT

Purpose: To adjust the sub-scan magnification for the master by changing the speed of the master feed motor.

Inputting a positive value stretches the image on the master. Inputting a negative value shrinks it.

Adjust standard: 300 ± 0.5 mm

1. Access SP6-42 (Image Adjustment Pattern Print), and then press the master making key. (☛5.1.10)
2. Exit the SP mode, print 5 copies at 90 cpm (speed “Fast”). Use the 5th print for the adjustment.
3. The black area should be 300 ± 0.5 mm in length.
4. If it is out of the standard, then adjust DIPSW103-5 to 103-8.

$$\{(300 - \text{Value}) / 300\} \times 100 = \pm X.X \%$$

DIPSW103-5	DIPSW103-6	DIPSW103-7	DIPSW103-8	Difference
ON	ON	ON	ON	+1.4%
OFF	ON	ON	ON	+1.2%
ON	OFF	ON	ON	+1.0%
OFF	OFF	ON	ON	+0.8%
ON	ON	OFF	ON	+0.6%
OFF	ON	OFF	ON	+0.4%
ON	OFF	OFF	ON	+0.2%
OFF	OFF	OFF	ON	0
OFF	OFF	OFF	OFF	0
ON	ON	ON	OFF	-1.4%
OFF	ON	ON	OFF	-1.2%
ON	OFF	ON	OFF	-1.0%
OFF	OFF	ON	OFF	-0.8%
ON	ON	OFF	OFF	-0.6%
OFF	ON	OFF	OFF	-0.4%
ON	OFF	OFF	OFF	-0.2%

6. DETAILED SECTION DESCRIPTIONS

6.1 MECHANISM OVERVIEW

6.1.1 MAJOR PARTS

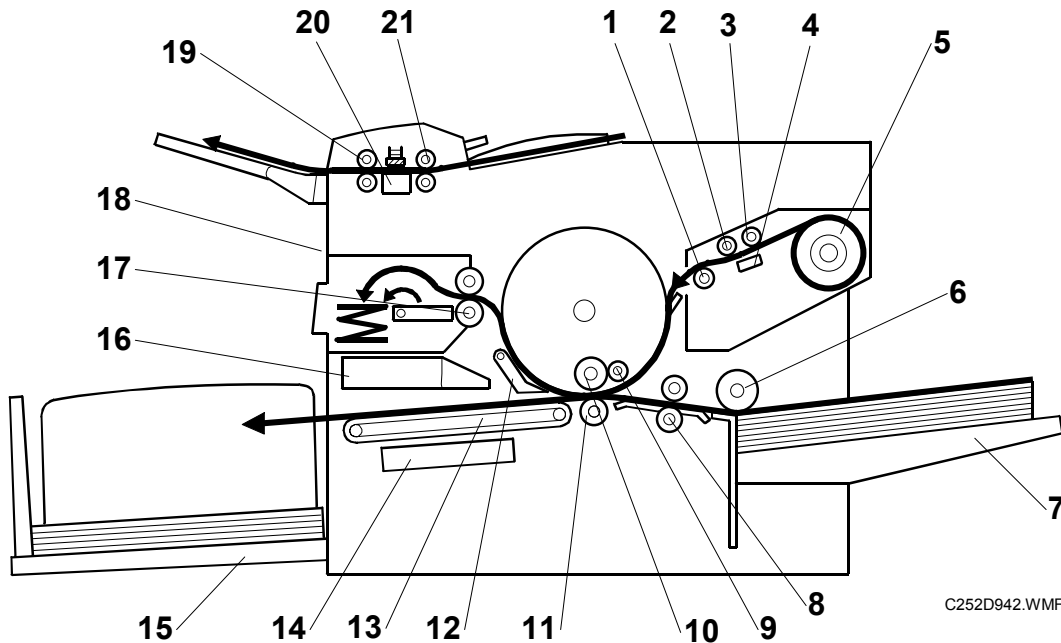

C252D942.WMF

- | | |
|-------------------------|--------------------------------|
| 1. Tension roller | 12. Exit pawl |
| 2. Master feed roller | 13. Transport belts |
| 3. Platen roller | 14. Vacuum fan motor |
| 4. Thermal head | 15. Paper delivery table |
| 5. Master roll | 16. Air knife fan motor |
| 6. Paper feed roller | 17. Master eject rollers |
| 7. Paper table | 18. Master eject box |
| 8. Registration rollers | 19. 2nd feed rollers |
| 9. Doctor roller | 20. CIS (Contact Image Sensor) |
| 10. Ink roller | 21. 1st feed rollers |
| 11. Press roller | |

6.1.2 ELECTRICAL COMPONENT LAYOUT

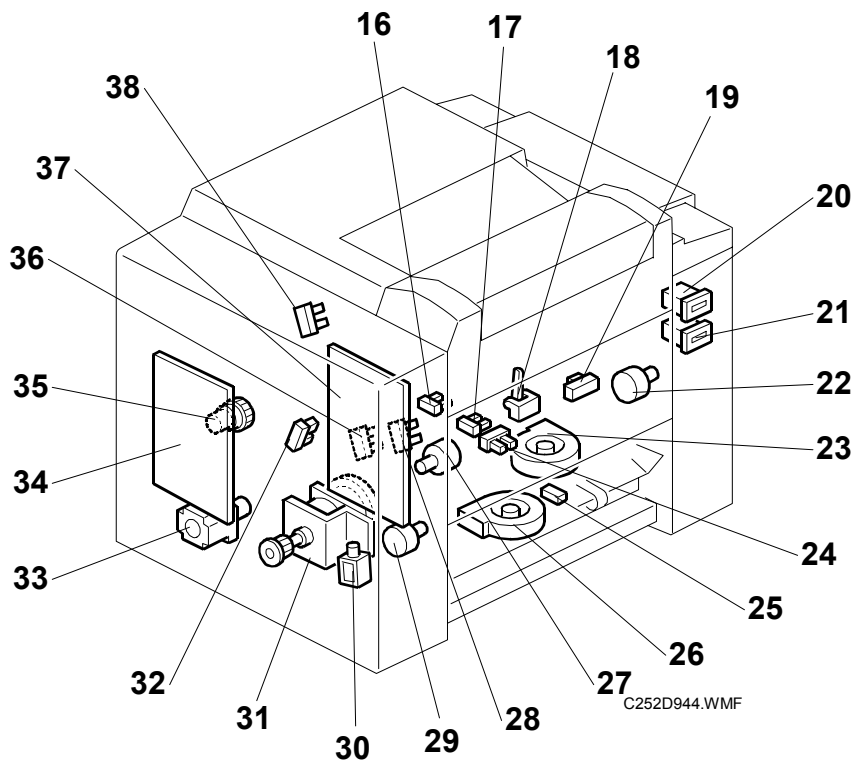
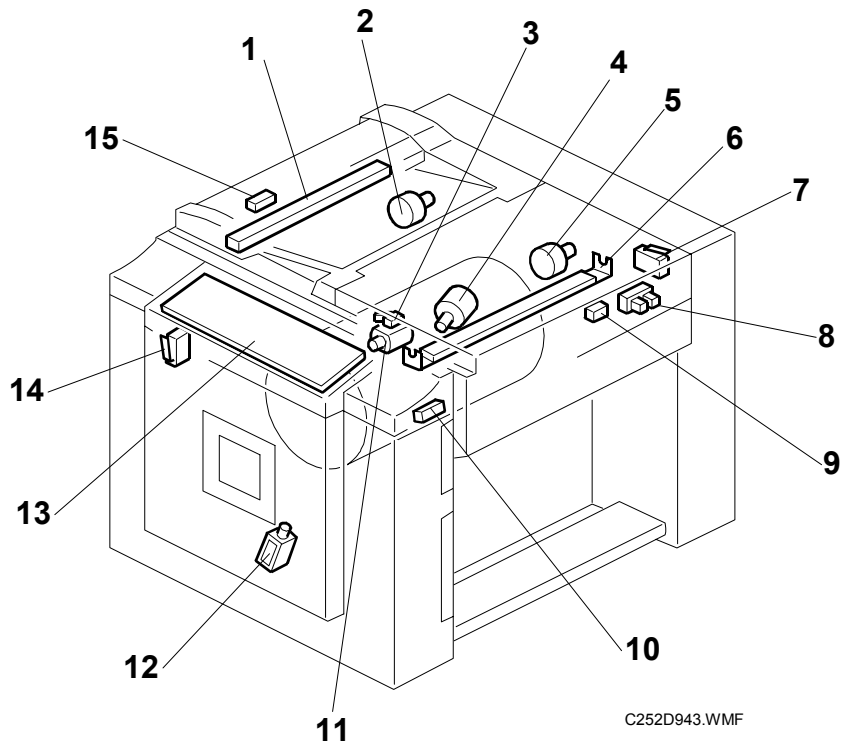

Boards

No.	Component	Function
13	Operation Panel Board	This board controls the operation panel.
34	Main Processing Unit (MPU)	Controls all machine functions, both directly and through other boards.
37	Power Supply Unit (PSU)	Provides dc power to the machine.

Motors

No.	Component	Function
2	Scanner Motor	Drives the scanner.
4	Ink Pump Motor	Drives the ink pump.
5	Master Feed Motor	Feeds the master to the drum.
11	Cutter Motor	Cuts the master.
22	Master Eject Motor	Sends used masters into the master eject box.
23	Air Knife Fan Motor	Rotates the fan to provide air to separate the leading edge of the paper from the drum.
26	Vacuum Fan Motor	Provides suction so that paper is held firmly on the transport belt.
27	Pressure Plate Motor	Drives the pressure plate.
29	Clamper Motor	Opens or closes the master clamper on the drum.
31	Main Motor	Rotates the drum, paper feed roller and transport belts.
33	Registration Motor	Feeds the paper to align it with the master on the drum.

Switches

No.	Component	Function
7	Right Side Cover Set Switch	Checks if the right side cover is closed.
14	Door Safety Switch	Checks whether the front door is properly closed.

Solenoids

No.	Component	Function
12	Front Pressure Release Solenoid	Releases the press roller to apply printing pressure.
30	Rear Pressure Release Solenoid	Releases the press roller to apply printing pressure.

Counters

No.	Component	Function
20	Master Counter	Keeps track of the total number of masters made.
21	Paper Counter	Keeps track of the total number of copies.

Sensors

No.	Component	Function
3	Cutter HP Sensor	Detects when the cutter is at the home position.
8	Master Set Cover Sensor	Checks if the master set cover is properly set.
9	Master End Sensor	Detects when the master making unit runs out of master roll.
10	Registration Sensor	Detects paper approaching the registration roller.
15	Document Sensor	Detects the leading edge of the original to determine when to turn off the scanner motor. Checks for original misfeeds.
16	Pressure Plate HP Sensor	Detects when the pressure plate is at the home position.
17	Pressure Plate Limit Sensor	Detects when the pressure plate is in the lowest position.
18	Master Eject Sensor	Detects used master misfeeds.
19	Drum Master Sensor	Detects if there is a master on the drum.
24	Eject Box Set Sensor	Checks if the master eject box is installed.
25	Paper Exit Sensor	Detects paper misfeeds at the exit.
28	Clamper Open Sensor	Detects if the clamper is in the open position.
32	Feed Start Timing Sensor	Determines the paper feed start timing.
36	Clamper Closed Sensor	Detects if the clamper is in the closed position.
38	Master Eject Position (Drum HP) Sensor	Detects when the drum is at the master eject position.

Others

No.	Component	Function
1	Contact Image Sensor (CIS)	This sensor reads and converts the light reflected from the document into an analog video signal.
6	Thermal Head	Burns the image onto the master.
35	Paper Feed Clutch	Transmits main motor drive to the paper feed rollers at the appropriate time.

6.1.3 DRIVE LAYOUT

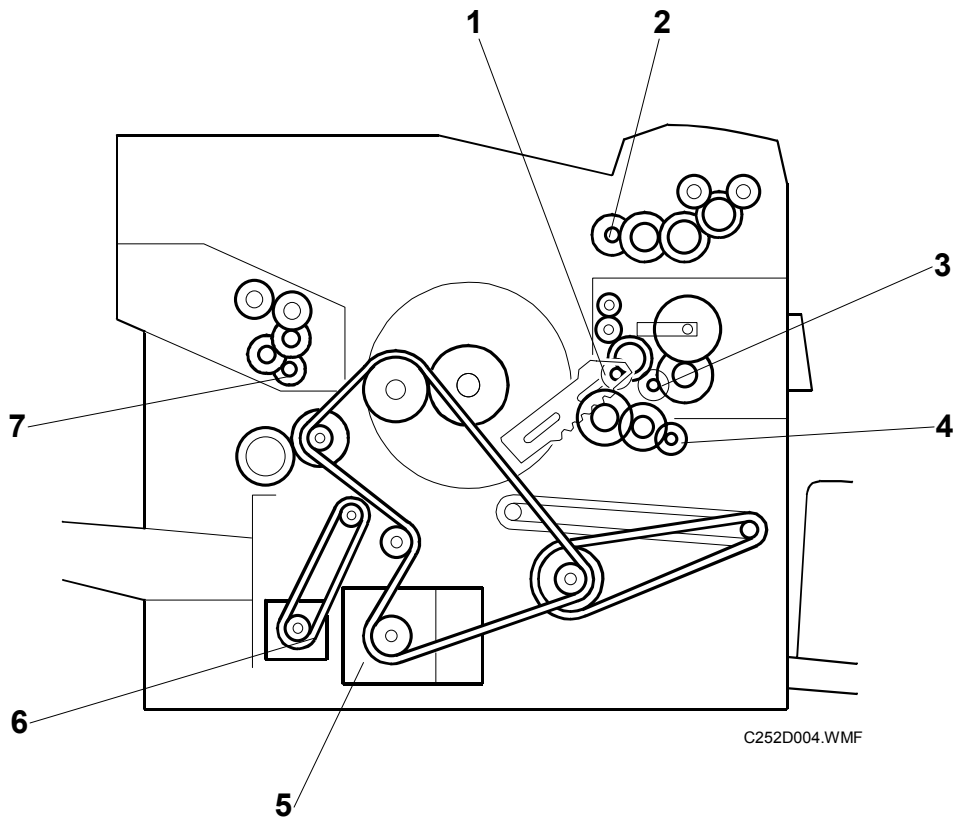

- 1. Master Eject Motor
- 2. Scanner Motor
- 3. Pressure Plate Motor
- 4. Clamper Motor
- 5. Main Motor
- 6. Registration Motor
- 7. Master Feed Motor

Detailed
Descriptions

6.2 MASTER EJECT UNIT

6.2.1 OVERVIEW

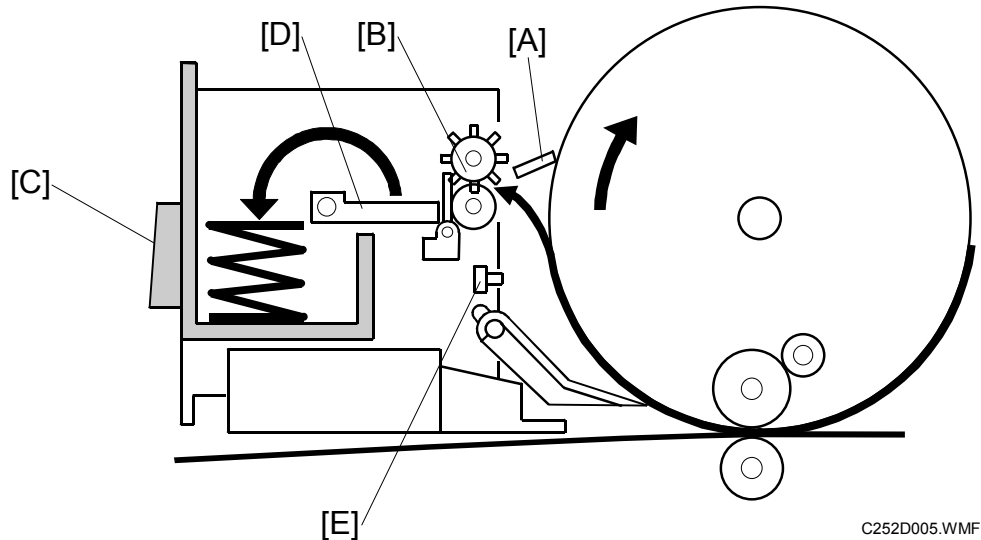

The master eject unit removes the used master from the drum. (🖨️📄: Digital Duplicators – Duplicating Process – Master Ejecting)

Procedure

The drum turns to the master eject position. Then the clamber [A] opens.

↓

Master eject rollers [B] pick-up the master's leading edge and feed the master for 0.6 seconds into the master eject box [C].

↓

The clamber then closes.

↓

The drum then turns at 30 rpm while the master eject rollers continue to feed the used master into the eject box.

↓

The drum stops after making about 1.5 turns. The master eject motor also stops. The pressure plate [D] then compresses the used masters in the eject box.

- The capacity is 30 used masters (under normal conditions)
- The master eject process is skipped when the drum master sensor [E] detects no master on the drum.

6.2.2 MASTER CLAMPER OPENING MECHANISM

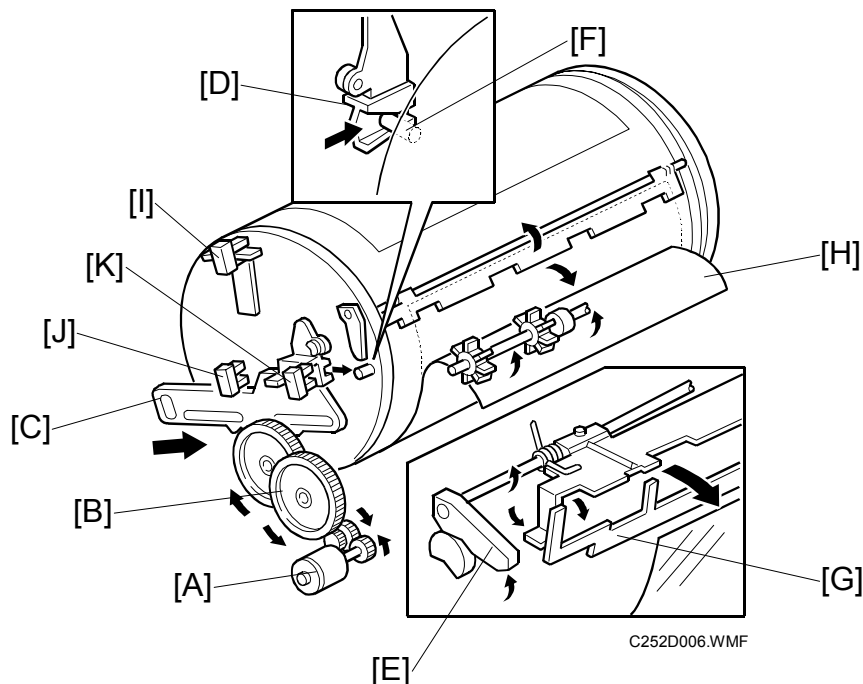

Clamper Mechanism

Clamper motor [A] - opens the clamper at the master eject position



Gears [B]



Link [C]



Drum guide [D] - moves and engages the pin on the rear flange of the drum



Lifts the clamper lever [E], and engages the drum pin [F]



The lever [E] lifts the master eject arm [G] to release the master's leading edge [H] from the clamper.

- NOTE:**
- 1) After the master making key is pressed and before the clamper motor starts, the master eject position sensor [I] is checked (the drum must be at the master eject position).
 - 2) The sensor actuators on the link [C], the clamper open sensor [J], and the clamper close sensor [K] determine the clamper open and close positions.
 - 3) The master clamper uses a magnetic plate to clamp the master's leading edge.
 - 4) The drum guide catches the drum at the master eject position while the master clamper is being opened. When the clamper motor turns on in reverse to close the clamper, the drum guide also disengages the pin and the drum can turn.

6.2.3 MASTER EJECT ROLLER MECHANISM

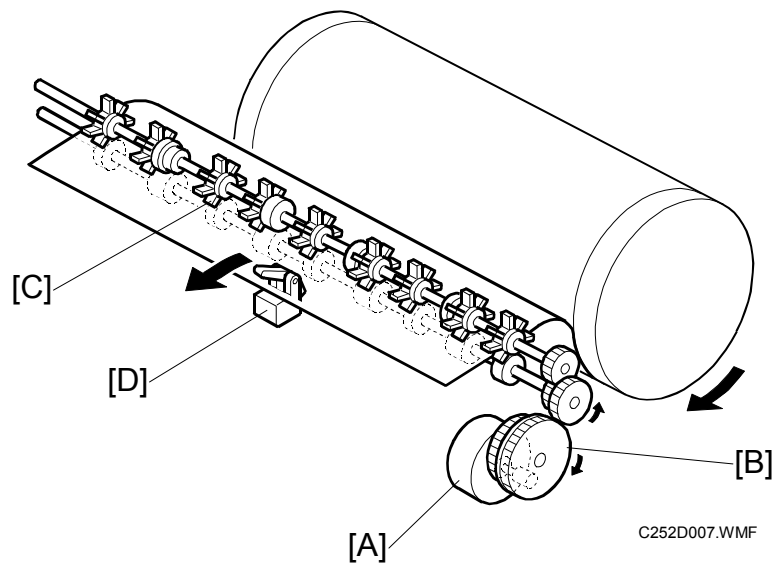

Mechanism

Master eject motor [A]



Gears [B]



Master eject rollers [C] – the upper roller has paddles



Pick up the master and feed it into the master eject box

Procedure

1. When the clamber is open and the master's leading edge is released from the clamber, the master eject motor turns on for 0.6 seconds to pick up the leading edge.
2. Then, the clamber motor reverses to close the clamber.
3. The drum then starts turning at the slower speed (30 rpm). At the same time, the master eject rollers turn again to feed the master into the master eject box.
4. When the drum reaches the master feed position, the master eject and drum motors stop. The master feed position is 109 encoder pulses after the feed start timing sensor is actuated.
5. During this process, the master eject sensor [D] detects master eject jams.
(☛4.4.1)

6.2.4 PRESSURE PLATE MECHANISM

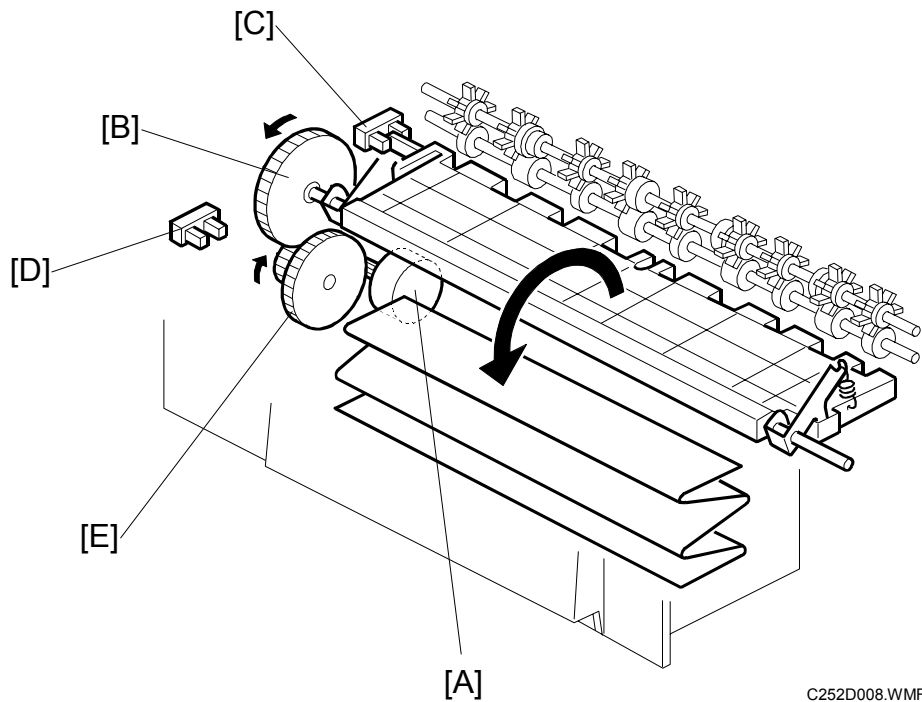

Mechanism

Pressure plate motor [A]



Gears [B]



Pressure plate rotates



Compresses the masters

Procedure

1. After the master has been ejected and the drum is stopped at the master feed position, the pressure plate motor turns until the actuator on the pressure plate actuates the limit sensor [D].
2. After master making and cutting, the motor reverses until the pressure plate home position sensor [C] is actuated, then it stops.
3. If the pressure plate limit sensor is not actuated within 2.8 seconds after the pressure plate motor rotates, the Full Master Eject Box indicator lights.
4. The idle gear [E] has a clutch to prevent motor overload.

6.3 SCANNER UNIT

6.3.1 SCANNER DRIVE

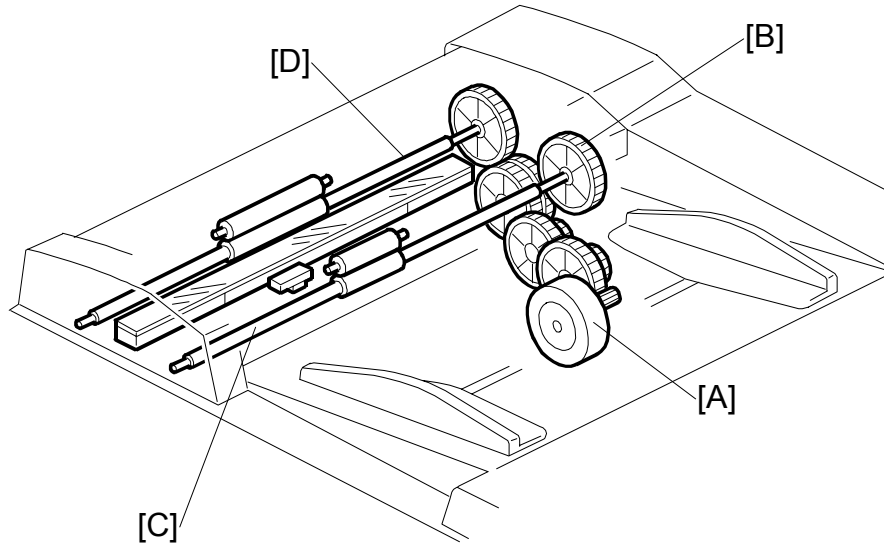

C252D009.WMF

Mechanism

Scanner motor [A]



Gears [B]



1st feed roller [C], 2nd feed roller [D] rotate



Feed the original

Procedure

1. When the master making key is pressed, the 1st/2nd feed rollers start moving the original forward at the same time.
2. The scanner motor stops at the original scanning position.
3. After the master eject process is finished, the master feed motor rotates and then the scanner motor turns on.
4. The scanner motor is turned off when the original is fed 60 mm after the document sensor switches off.

6.4 IMAGE PROCESSING

6.4.1 IMAGE PROCESSING FLOW

Image processing is done by the IPU (Image Processing Unit) on the MPU board, following the steps shown below.

Shading Correction



Gamma Correction



MTF Filtering



Grayscale Processing

Shading Correction:

Corrects errors in the signal level for each pixel using the white plate.

Gamma Correction:

Background erase

MTF Filtering:

Reduces the contrast.

Grayscale Processing:

Compares each pixel with surrounding pixels to enhance the image.

- Text mode: Binary processing
- Photo mode: Error diffusion

6.5 MASTER FEED

6.5.1 OVERVIEW

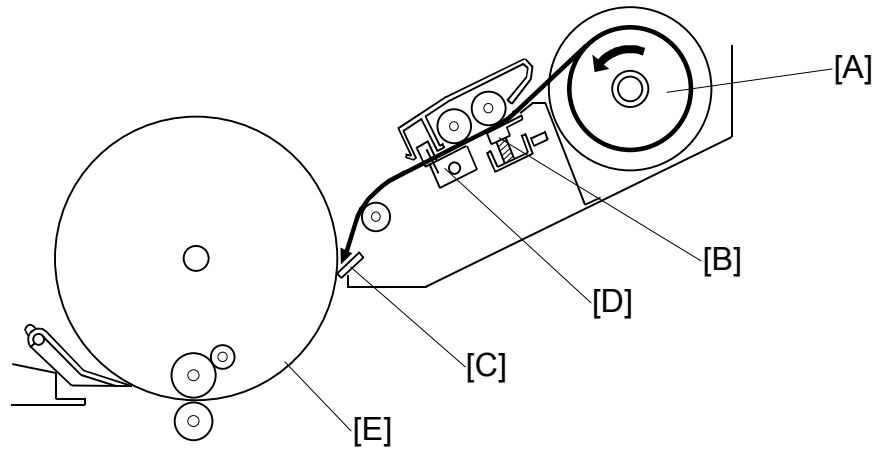

C252D010.WMF

The master feed unit makes an image on the master and feeds the master to the drum. (📖 **CT**: Digital Duplicators – Duplicating Process – Master Feeding)

Procedure

The machine feeds the master from the master roll [A].

↓

The thermal head [B] makes an image on the master.

↓

Clamber [C] opens. (The drum is at the master feed position.)

↓

The clamber clamps the master. At this time, the cutter [D] cuts the master.

↓

The master is wrapped around the drum [E].

6.5.2 MASTER FEED MECHANISM

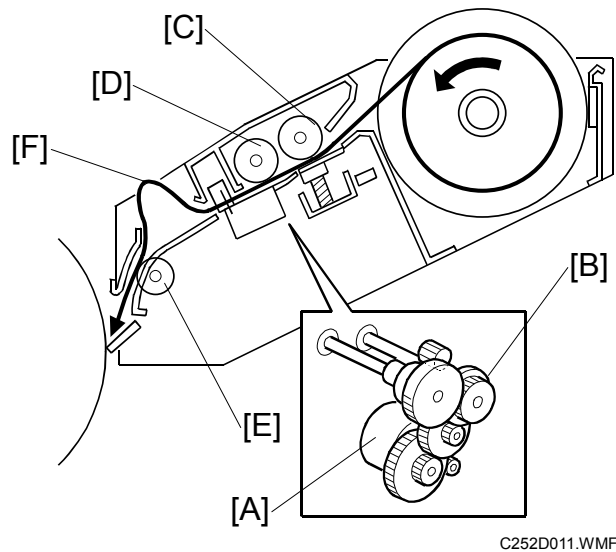

C252D011.WMF

Mechanism

Master feed motor [A] (stepper motor)



Gears [B]



Platen roller [C], master feed roller [D]



Feeds the master (The thermal head makes an image on the master.)

Procedure

1. After the old master has been ejected, the drum stops at the master feed position and the master clamper opens, ready to clamp the new master.
2. When the clamper is open, the tension roller releases and the master is fed to the clamper on the drum. For details of the tension roller, see section 6.5.3.
3. After the clamper closes, the master feed motor feeds the master while the drum rotates intermittently at 30 rpm. The intermittent rotation keeps a buckle [F] in the master above the master feed guide to absorb shocks from the wrapping operation.
4. The tension roller [E] keeps the master under tension. This roller reduces the master making time, because it allows the drum to turn continuously during wrapping. Without this roller, if the drum kept turning, the master would crease.
5. The main motor turns off when the drum is at the master eject position. The master feed motor continues to feed the master until master making completed. Then the master feed motor turns off, and cutting is done.

NOTE: Springs press the thermal head against the platen roller. The pressure is applied when the master set cover, which includes the platen roller, is closed.

6.5.3 CLAMPER AND TENSION ROLLER MECHANISM

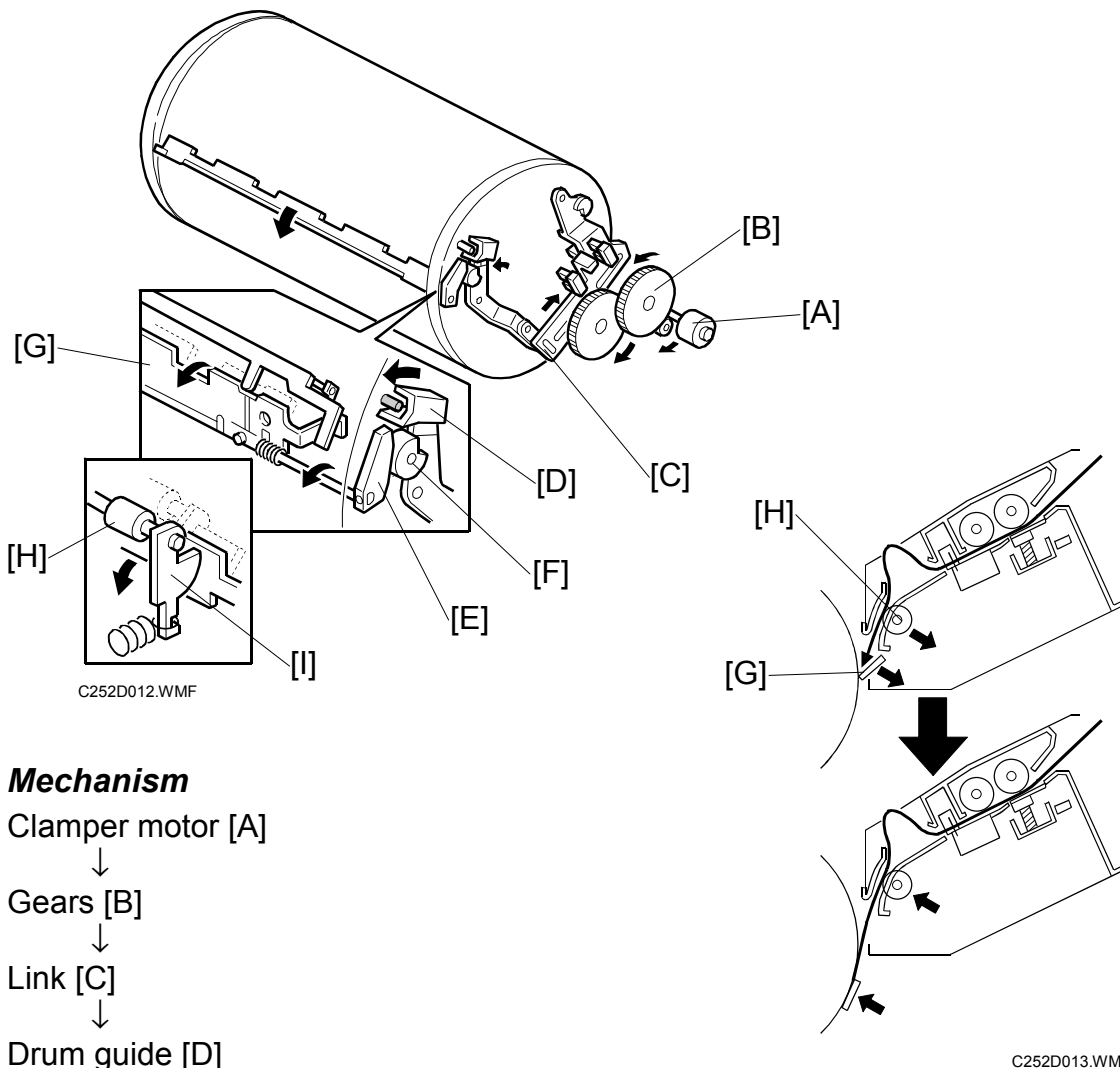

Mechanism

Clamber motor [A]
 ↓
 Gears [B]
 ↓
 Link [C]
 ↓
 Drum guide [D]
 ↓
 Lifts the lever [E], engages and locks the drum pin [F], opens the clamber plate [G].
 ↓
 Releases the tension roller [H].
 ↓
 Feeds the master into the clamber.

Procedure

- When the old master has been ejected, the drum is stopped at the master feed position. The master clamber clamps the leading edge of the new master before the drum starts to turn again.
- The tension roller [H] normally presses against the master feed guide plate to apply tension to the master during master wrapping. When the clamber opens, it pushes the tension roller arms [I] and moves the tension roller away from the guide plate to allow the master to be fed into the master clamber.
- Clamber mechanism: See the Master Eject section

6.5.4 CUTTER MECHANISM

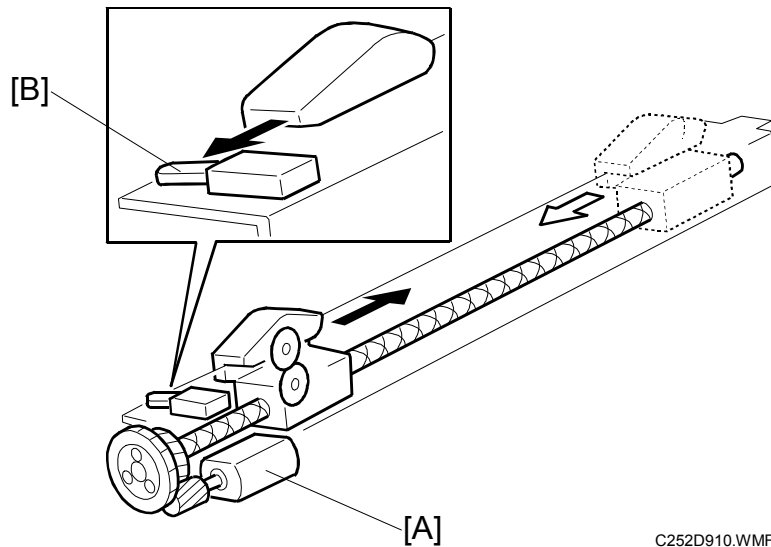

C252D910.WMF

[A]: Cutter motor

[B]: Cutter HP sensor

- When the cutter starts, the drum is stopped at the master eject position (drum HP).
- The cutter moves backwards and forwards. While the cutter travels towards the rear (non-operation side), it cuts the master. The motor turns in one direction. The cutter returns to the home position when it reaches the rear because of the two different spiral threads on the screw shaft.
- The cutter usually cuts a master of about 470 mm in length.

After cutting, the drum starts turning again to wrap the remaining part of the master around the drum. The leading edge of the master that was cut remains at the cutting position, ready to make the next master.

6.5.5 MASTER SET COVER SENSOR

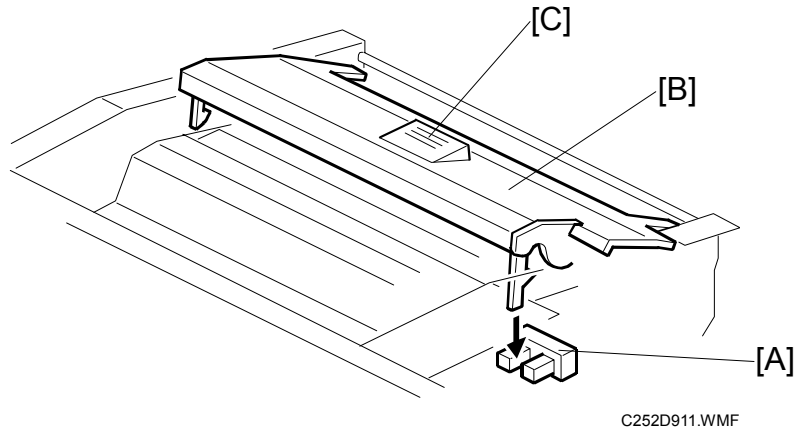

[A]: Master set cover sensor

[B]: Master set cover

- If the cover is closed properly, the release button [C] rises.

6.6 DRUM

6.6.1 OVERVIEW

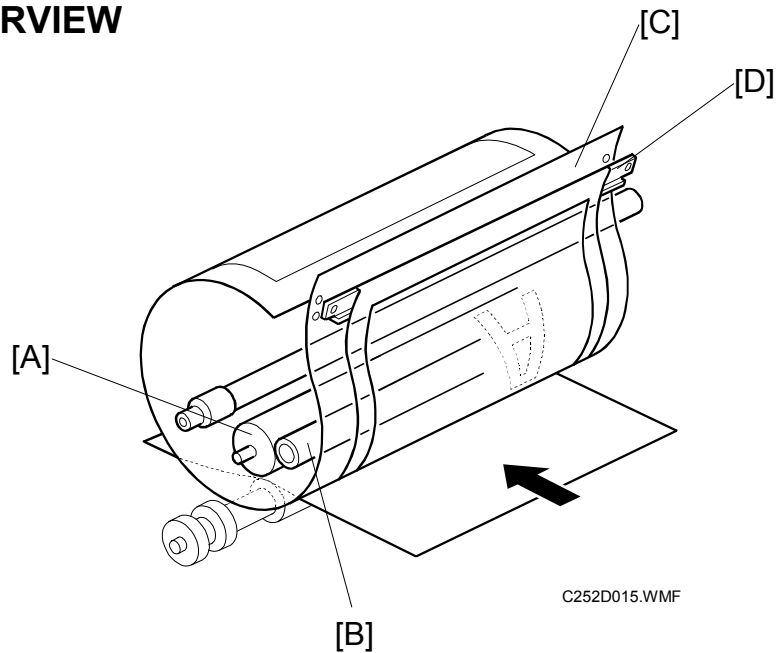

Procedure

Ink is supplied inside the drum, through the drum shaft.



The ink roller [A] and the doctor roller [B] spread the ink evenly on the screens.



Ink passes through the metal screen [C].



Ink passes through the cloth screen [D].



Ink passes through the holes in the master that were made by the thermal head.



Ink reaches the paper.

- NOTE:**
- 1) The drum is driven by the main motor and turns only clockwise.
 - 2) The main motor speed and the drum stop positions are controlled by monitoring the motor encoder.
 - 3) The ink pump, which is outside the drum, supplies ink from the ink cartridge into the drum through the drum shaft.

6.6.2 DRUM DRIVE MECHANISM

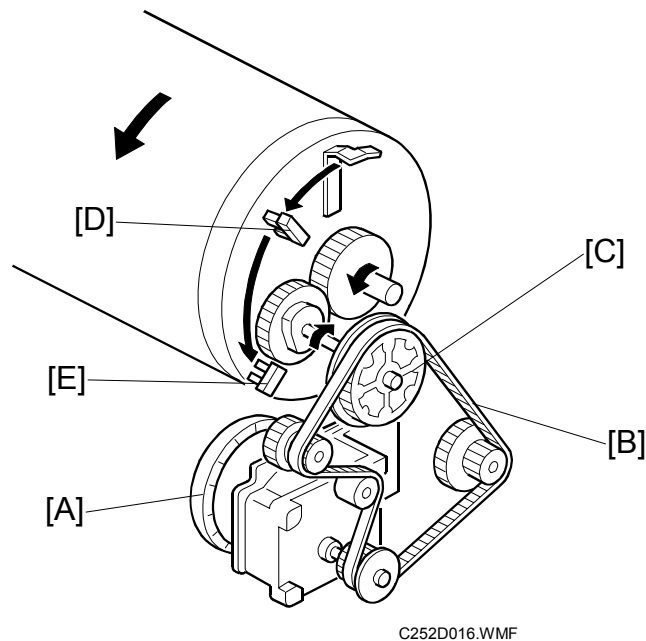

Mechanism

Main motor [A] (dc motor)



Belt [B]



Gears [C]



The drum rotates.

- NOTE:**
- 1) The main motor encoder sends pulses to the main motor control board (1000 pulses = 360 degrees).
 - 2) The CPU monitors the pulses and controls the drum speed and stop positions.
 - 3) The drum has two sensors;
 - Master eject sensor [D] (master eject position and drum home position)
 - Feed start timing sensor [E]
 - 4) The drum has two stop positions;
 - Master eject (drum home) position
 - Master feed position (feed start timing sensor + 111 pulses)

6.6.3 INK SUPPLY MECHANISM

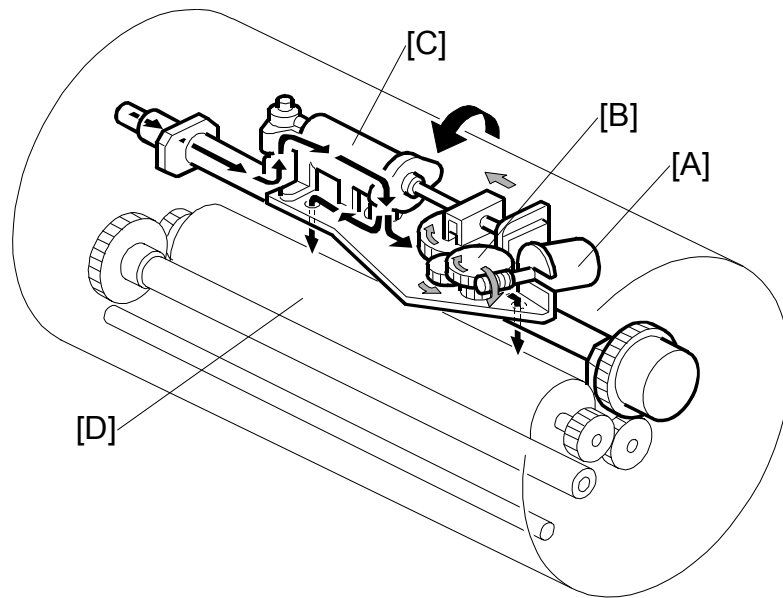

C252D914.WMF

Mechanism

Ink pump motor [A]



Gears [B]



Gear rotation converted into piston motion.



Supplies ink from the ink cartridge to the ink roller via the pump [C]. Ink drops through holes in the ink roller [D].

NOTE: There are four holes in the shaft for the B4 size drum, and two holes for the Legal size drum.

6.6.4 INK ROLLER MECHANISM

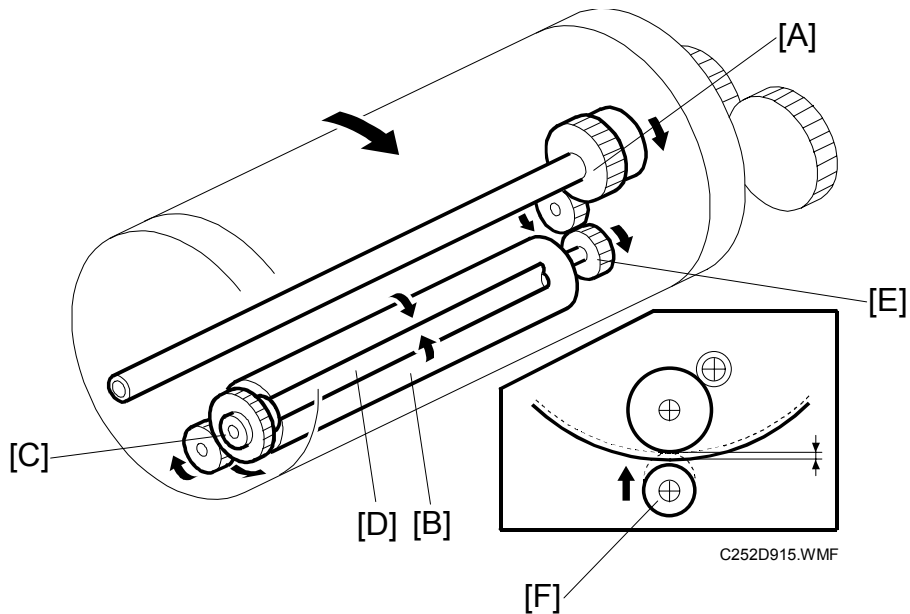

Mechanism

Main motor



Gears [A]



Ink roller [B] rotates



Gears [C]



Doctor roller [D] rotates



The doctor roller squeezes the ink on the ink roller to produce an even thickness of ink on the ink roller.

- NOTE:**
- 1) The ink roller drive gear [E] has a one-way clutch to prevent the ink roller from being turned in reverse if the drum is manually turned in reverse.
 - 2) The ink roller does not touch the metal screen when the machine is not printing.
 - 3) During printing, the ink on the ink roller is applied to the paper through the holes in the screens and the master. This happens when the press roller [F] under the drum moves up to press the drum screen and the master against the ink roller. (☛📖: Digital Duplicators – Ink Supply Control)

6.6.5 INK SUPPLY CONTROL

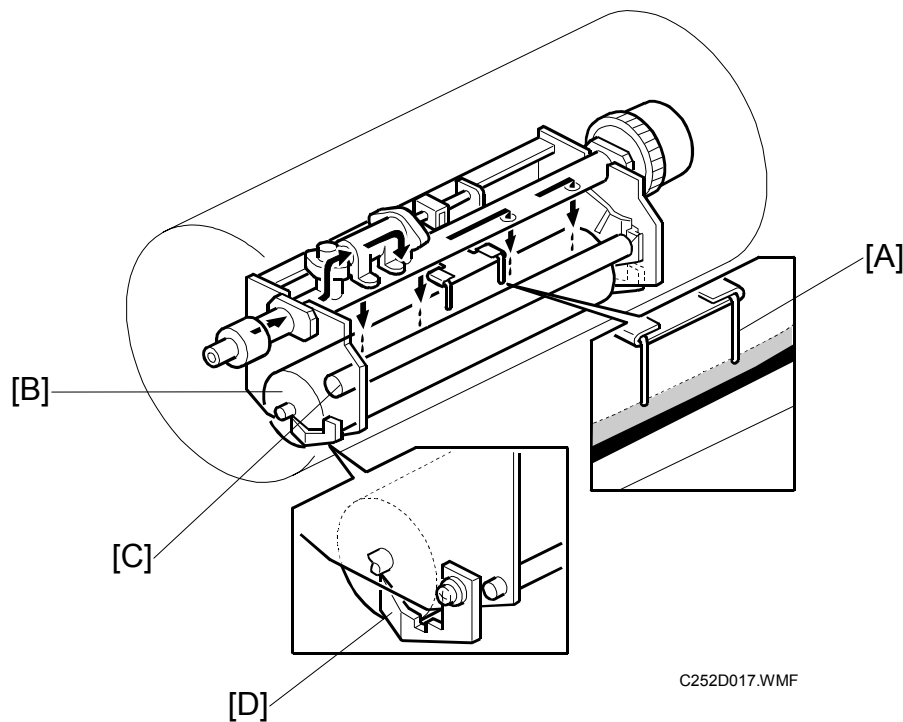

Mechanism

When the ink level is low, the pins [A] do not touch the ink.



The ink pump motor (6.6.3) keeps the ink level normal by supplying ink when the level is low.

- NOTE:**
- 1) The ink detection pins [A] detect the capacitance between the ink roller [B] and doctor roller [C].
 - 2) If the pins detect an insufficient amount of ink after activating the ink pump motor for 40 seconds, a "no ink condition" is detected. The add ink indicator on the operation panel will light.
 - 3) There is an ink supply mode, which is useful when installing a new drum. When the "Clear/Stop" key is pressed while holding down the "0" key, the drum turns 40 rotations to supply ink inside the drum.
 - 4) The ink roller blades [D] on both ends of the ink roller scrape off the built-up ink on the ends of the ink roller.

6.6.6 DETECTION OF MASTERS ON THE DRUM

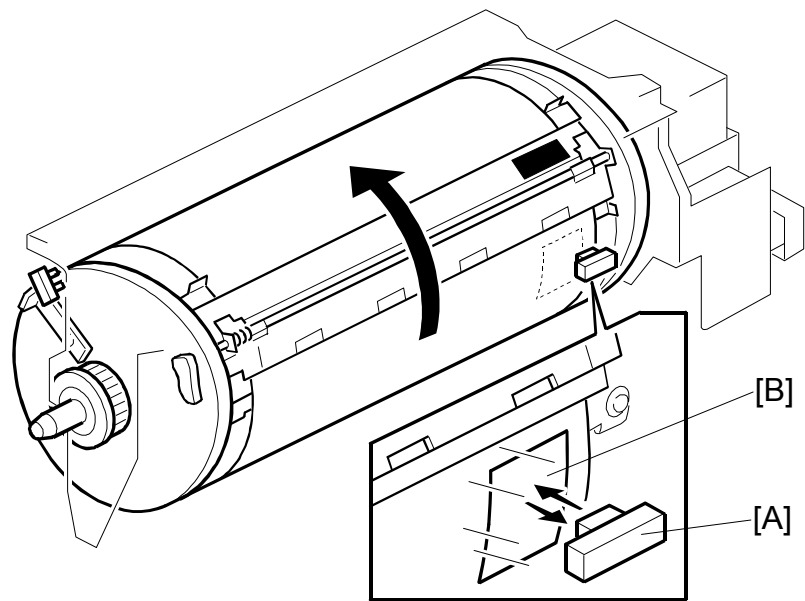

C252D018.WMF

[A]: Drum master sensor
[B]: Black patch on the screen
[C]: Black patch on the clamber

- The drum master sensor [A] detects whether there is a master on the drum.
- When there is a master on the drum, the black patch [B] is covered and the sensor detects the light reflected from the master. When there is no master on the drum, the black patch [B] is exposed. The black patch does not reflect light back to the sensor. Because of this, the master eject process can be skipped when a new master is being made, if no master is detected on the drum.

6.7 PAPER FEED

6.7.1 OVERVIEW

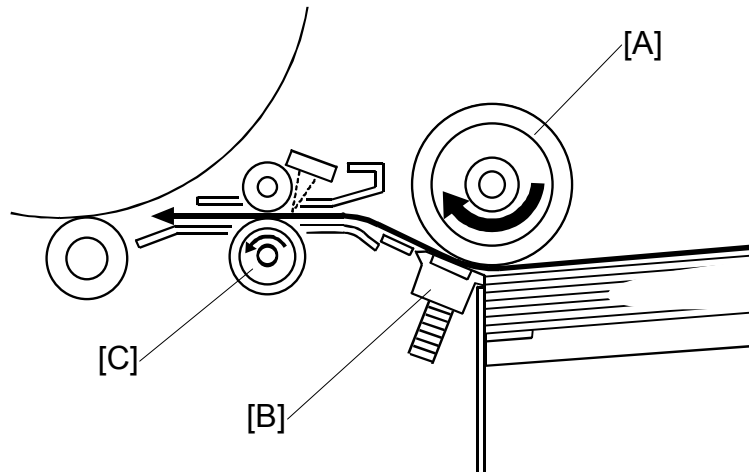

C252D019.WMF

This mechanism feeds blank copy paper into the printer. (🖨️📄: Handling Paper – Paper Feed – Paper Feed Methods – Friction Pad)

Mechanism

The paper table is lifted manually.



The feed roller [A] and the separation pad [B] only allow one sheet to pass.



The registration rollers [C] feed the paper.



The print is made.

NOTE: 1) The main motor drives the feed roller.
2) A dedicated stepper motor (registration motor) controls the registration roller.

6.7.2 PAPER FEED MECHANISM

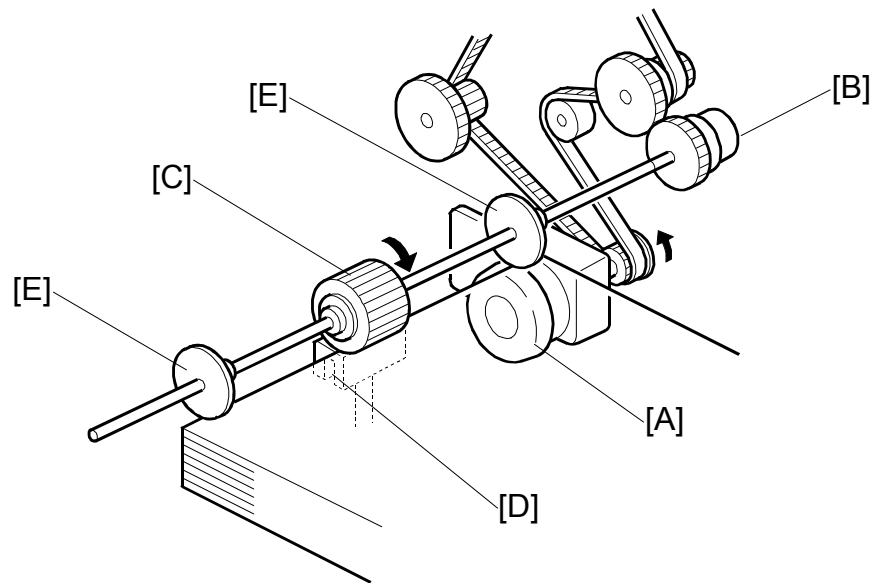

C252D020.WMF

Mechanism

Main motor [A]



Belt and gears



Paper feed clutch [B]



Turns the paper feed roller [C]

- NOTE:** 1) The machine uses a friction pad [D] and feed roller system. (☛ **CT**): Handling Paper – Paper Feed – Paper Feed Methods – Friction Pad)
- 2) When the feed roller stops and paper is fed by the registration rollers, the one-way clutches in the feed roller ensure that these rollers do not resist paper feed.
- 3) The guides [E] help to feed paper that is not perfectly flat. The guides are not used normally.

6.7.3 PAPER FEED / SEPARATION PRESSURE MECHANISM

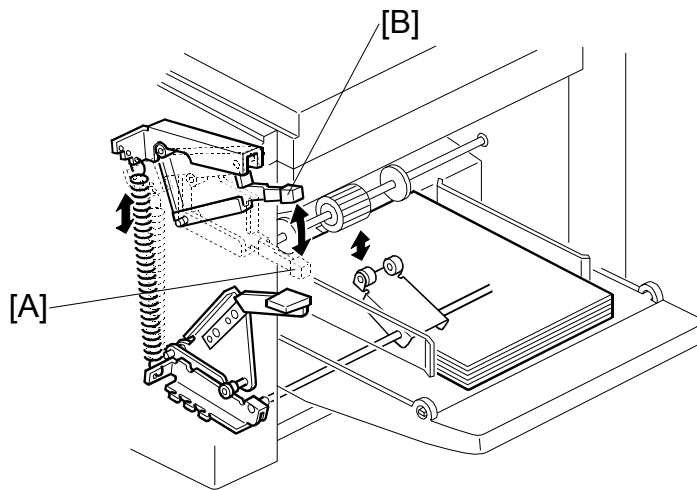

C252D030.WMF

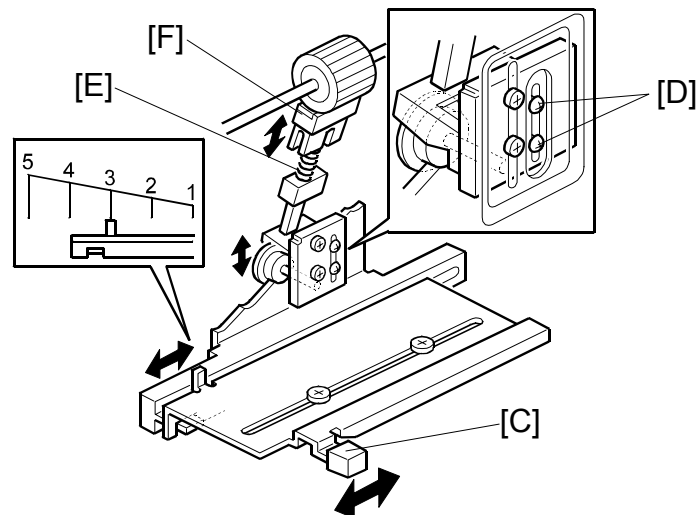

C252D021.WMF

[A]: Standard position (35 to 81.5 g/m², 9.3 to 21.6 lb.)
 [B]: Thick paper position (81.6 to 127.9 g/m², 21.7 to 34.0 lb.)

- The user can change the feed roller pressure by changing the position of the pressure adjustment lever [A].
- If paper feed jams frequently occur, the lever should be moved to adjust the pressure.
- If non-feed or multi-sheet feed problems still occur, the paper separation pressure can also be adjusted using the separation pressure slider [C].
- The default position of the slider [C] is position 3.
- By loosening then moving the screws [D] up or down, the spring [E], which applies pressure to the friction pad block [F], moves up or down. (This should be done by a technician; see 3.7.3)
- The default position of the screw [D] is at the lowest position.

6.7.4 REGISTRATION ROLLER MECHANISM

Registration Roller Drive

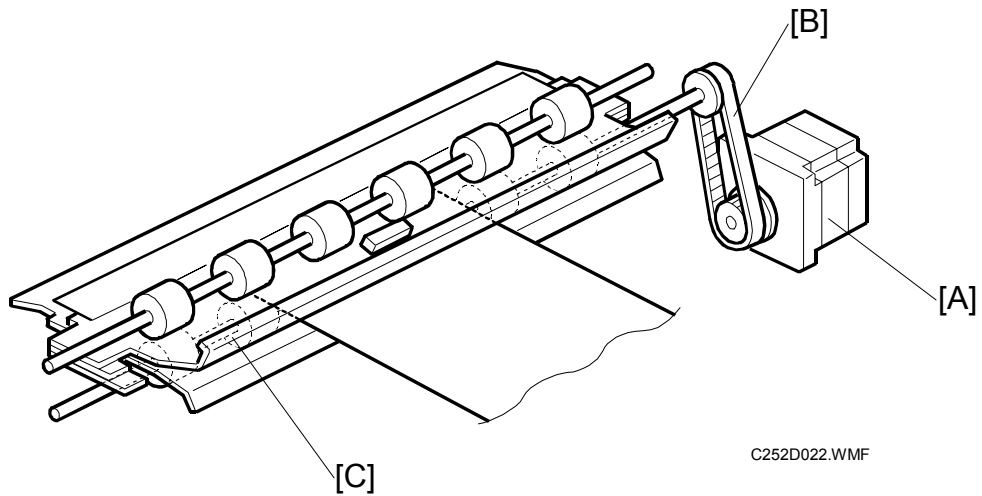

Registration motor [A]



Belt [B]



Turns the lower registration roller [C]

- NOTE:**
- 1) The CPU controls the registration roller start timing to synchronize the print paper with the image on the master on the drum.
 - 2) The motor speed depends on the selected printing speed.
 - 3) By pressing the image position keys on the operation panel, the registration motor start timing is changed.

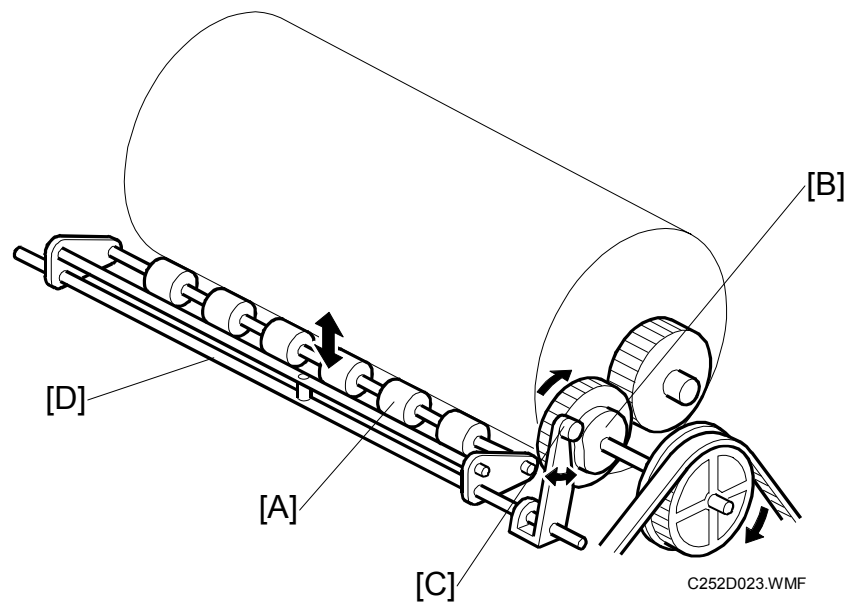
Registration Roller Up/Down Mechanism

- After the printing paper is caught between the drum and the press roller, the registration motor stops and the upper registration roller [A] is released from the lower registration roller. This is to prevent interference from the registration rollers while the drum and press roller transport the paper.
- When the high point of the cam [B] on the drum drive gear reaches the cam follower [C], the shaft [D] rotates clockwise (as seen from the operation side) to release the upper registration roller [A] from the lower registration roller.

6.7.5 REGISTRATION SENSOR CLEANING

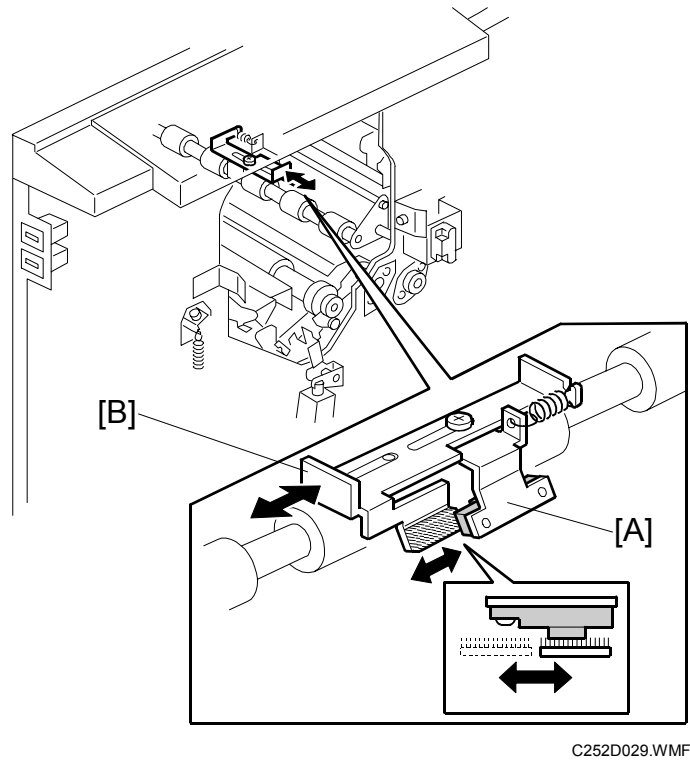

NOTE: This mechanism is attached only for the China model.
Dust on the registration sensor [A] can be removed by operating a lever [B]. The technician should do this every visit.

6.7.6 PRINTING PRESSURE MECHANISM

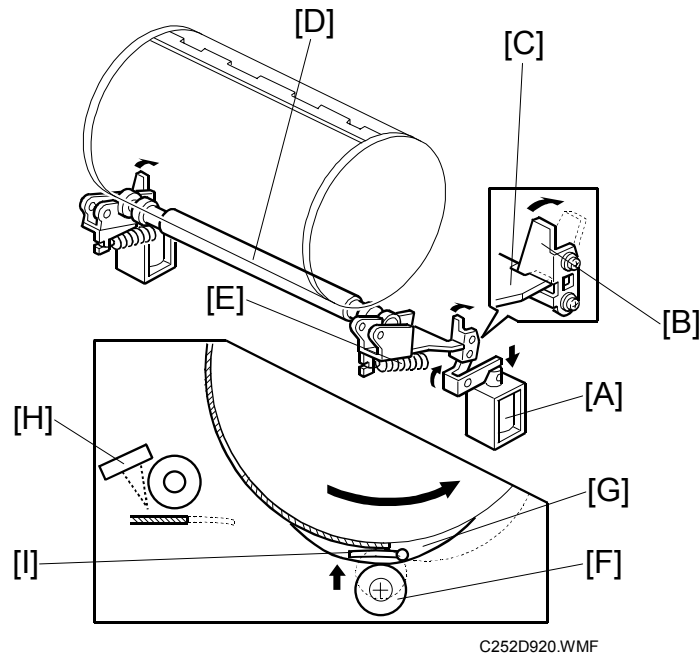

- When not in the printing cycle, the two solenoids [A] stay off and the stoppers [B] lock the brackets [C] to keep the press roller [D] away from the drum.
- When the 1st sheet of paper is fed, the solenoid is energized but the brackets are still locked by the stoppers due to strong tension from the springs [E].
- When the high points of the cams [G] on the front and rear drum flanges reach the cam followers [F] on both sides of the press roller shaft, a small clearance is made between the stoppers and the brackets. The two solenoid plungers are pulled down at the same time, releasing the stoppers from the brackets.
- Printing pressure is applied by tension from the springs [E] when the cam followers [F] come off the high points of the cams [G].
- During the printing cycle, the solenoids stay on. However, if paper does not reach the registration sensor [H] at the proper time (when the cam follower is on the high point of the cam), the solenoids are de-energized to lock the brackets.
- The printing pressure is released when the cams push down the cam followers so that the press roller does not contact the master clamber [I].
- After printing is finished, the solenoids de-energize and the springs push the stoppers back. Before the drum returns to the home position, the stoppers lock the brackets again when the cams push down the cam followers.

6.7.7 RE-FEEDING MECHANISM

If the registration sensor detects a non-feed, the machine tries again. However, if the machine detects a non-feed the second time, the following three indicators light: "A jam indicator", "⚠", "🛑". Also see 'Paper End Detection'.

6.7.8 PAPER TABLE MECHANISM

Table lifting / lowering

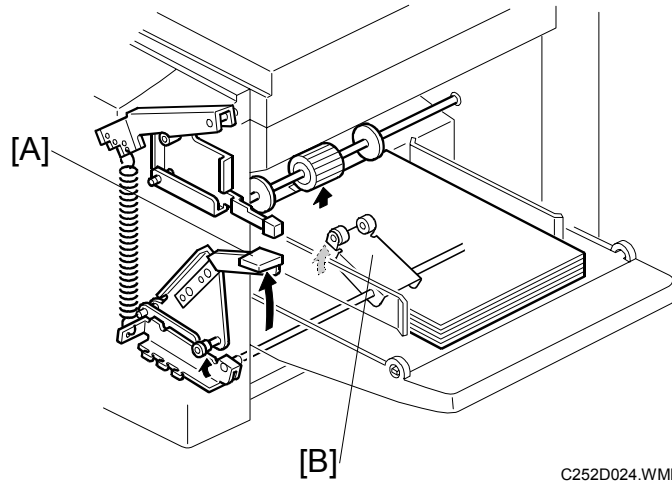

Mechanism

The user moves the paper feed tray adjustment lever [A] up or down.



Link and spring



Plate [B]



Lift or lower the paper table.

- When the user raises the paper feed tray adjustment lever [A], the plate [B] lifts the paper table to the paper feed position.

Paper end detection

There is no paper end sensor.

The registration sensor detects when the paper on the table runs out. Then, the following three indicators light: “A jam indicator”, “⚠”, “📄”.

NOTE: This is the same condition as the paper jam detected during the refeed process (section 6.7.7); the machine cannot distinguish between these two conditions. The user must check for both paper jam and paper end at this time.

After the front cover is opened and closed, only the paper end indicator remains lit.

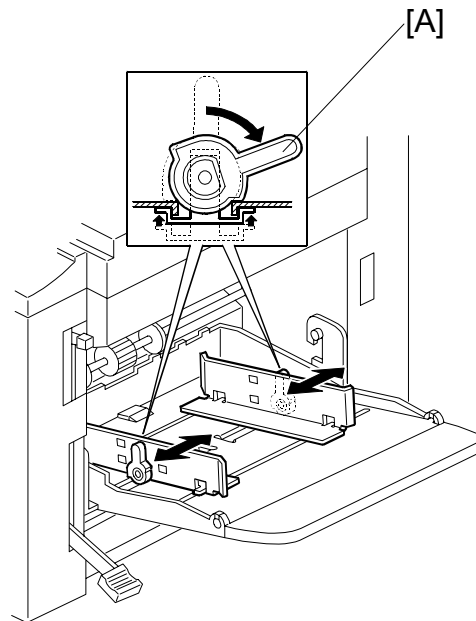
Table side fence lock mechanism

C252D025.WMF

The lock levers [A] hold the side fences in position.

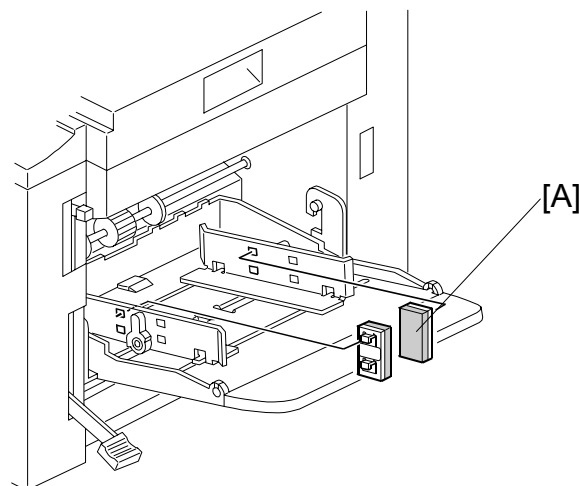
Side fence friction pads

C252D026.WMF

Detailed
Descriptions

- The two side fence friction pads [A] are included as accessories. These are not used normally, but if paper multi-feed frequently occurs, the friction pads can be installed to apply stopping pressure to the paper. These are especially useful when thin paper is used.
- The users can install the side fence friction pads if they are using thin paper.

6.8 PAPER DELIVERY

6.8.1 OVERVIEW

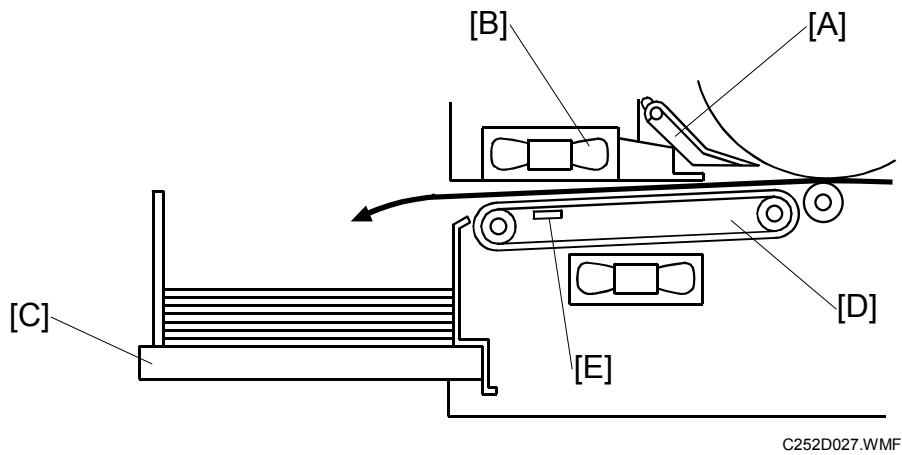

Procedure

The exit pawl [A] and the air knife [B] separate the paper from the drum.

↓

The paper is fed to the paper delivery table [C] by the paper delivery unit [D].

The paper exit sensor [E] is used for jam detection. (●4.4.6)

6.8.2 PAPER DELIVERY UNIT DRIVE MECHANISM

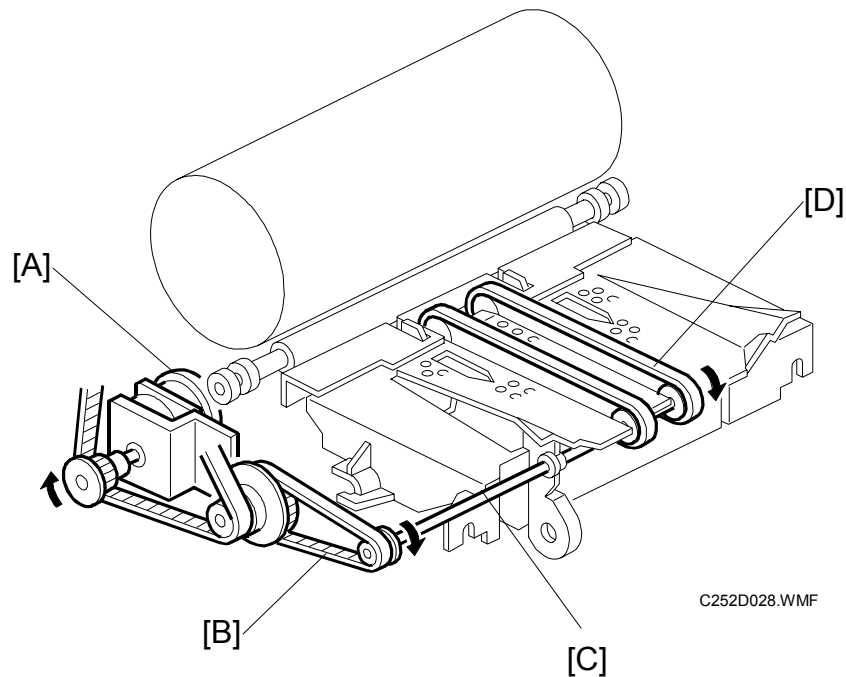

Mechanism

Main motor [A]



Belt and gear [B]



Shaft [C]



Rotates the transport belts [D].

NOTE: 1) The vacuum fan motor inside the unit holds the paper against the belts [D] to deliver the paper to the delivery table.

2) The transport belt rotation speed depends on the selected print speed.

6.8.3 PAPER SEPARATION FROM THE DRUM

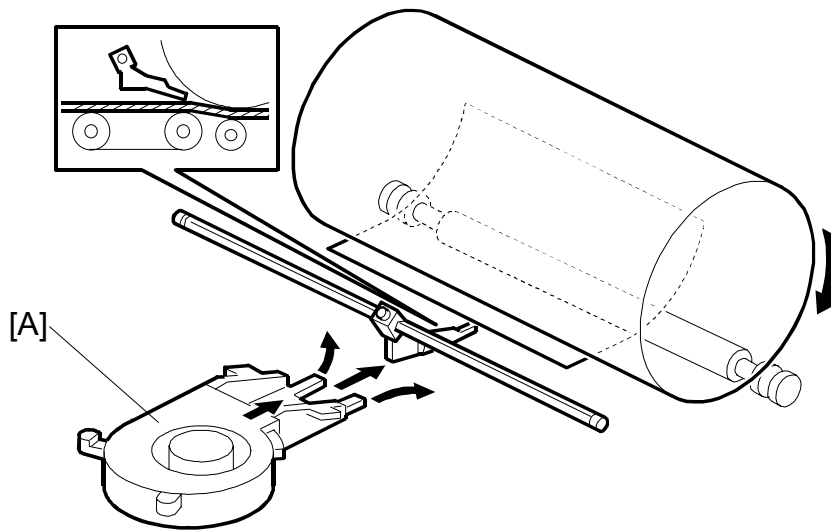

C252D922.WMF

Air knife

- The air from the air knife fan motor [A] separates the paper from the drum.
- The air knife fan motor starts blowing air when the print start key is pressed or when master cutting is finished. The paper passes under the exit pawl and is delivered to the delivery table.

6.8.4 EXIT PAWL DRIVE MECHANISM

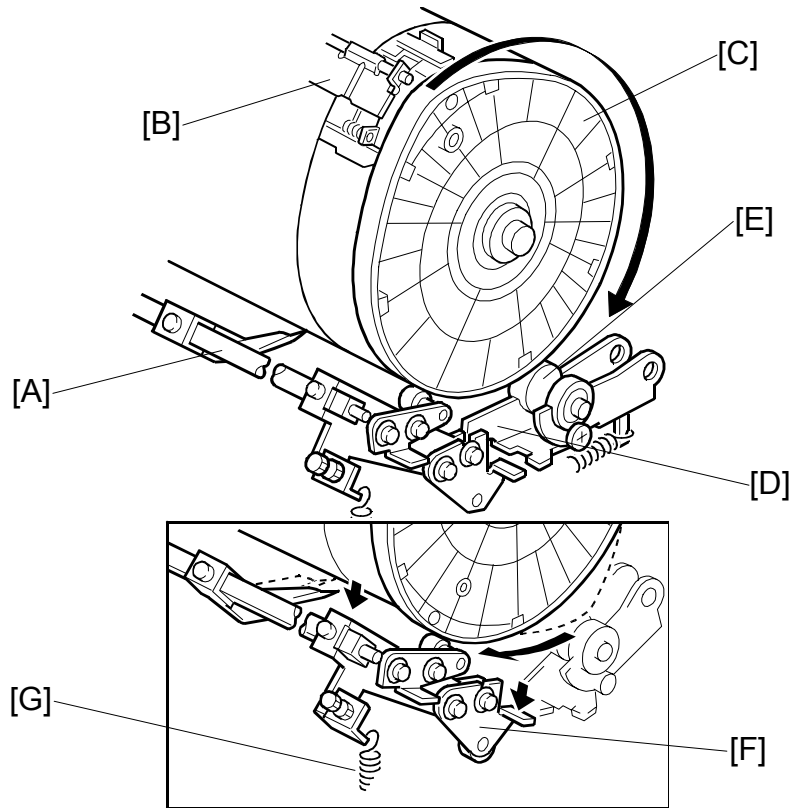

C252D923.WMF

- During printing, the distance between the exit pawl [A] and the drum is very small, to prevent paper wrap jams. However, when the master clamber [B] approaches the exit pawl (as the drum turns), the pawl has to be moved away from the drum to prevent it from being damaged by the master clamber. This is controlled by the front drum flange [C], which is cam-shaped, and the cam follower [E] on the exit pawl shaft.
- When the cam follower is not pushed out by the drum flange, the exit pawl closely approaches the drum surface, due to the tension from a spring [G].
- As the master clamber approaches the exit pawl, the high point of the drum flange cam [C] moves into contact with the cam follower [E] pushing it down. This moves the cam follower arm [F] downwards. The pawl shaft turns clockwise to move the pawl away from the drum.

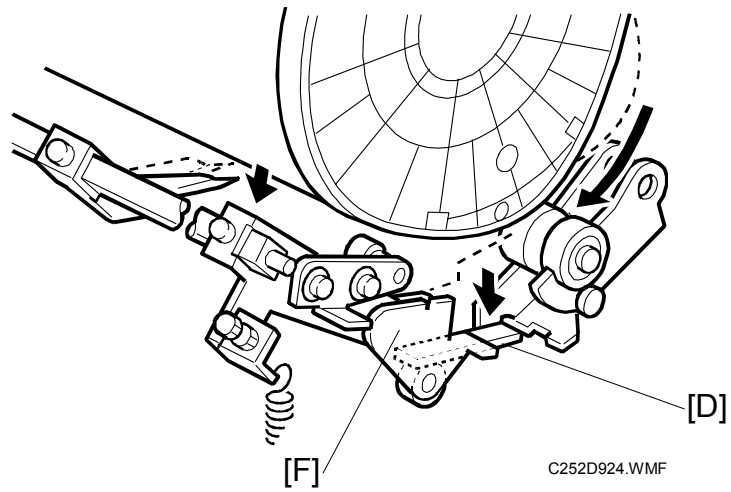

- When printing finishes and the printing pressure is released, the cam follower arm [F] is engaged by the printing pressure release arm [D] and held in the lower position. Therefore, after printing finishes, the cam follower is out of contact with the cam, and the exit pawl moves away from the drum to its normal position.

6.9 TIMING CHART

6.9.1 MASTER EJECT / MASTER FEED

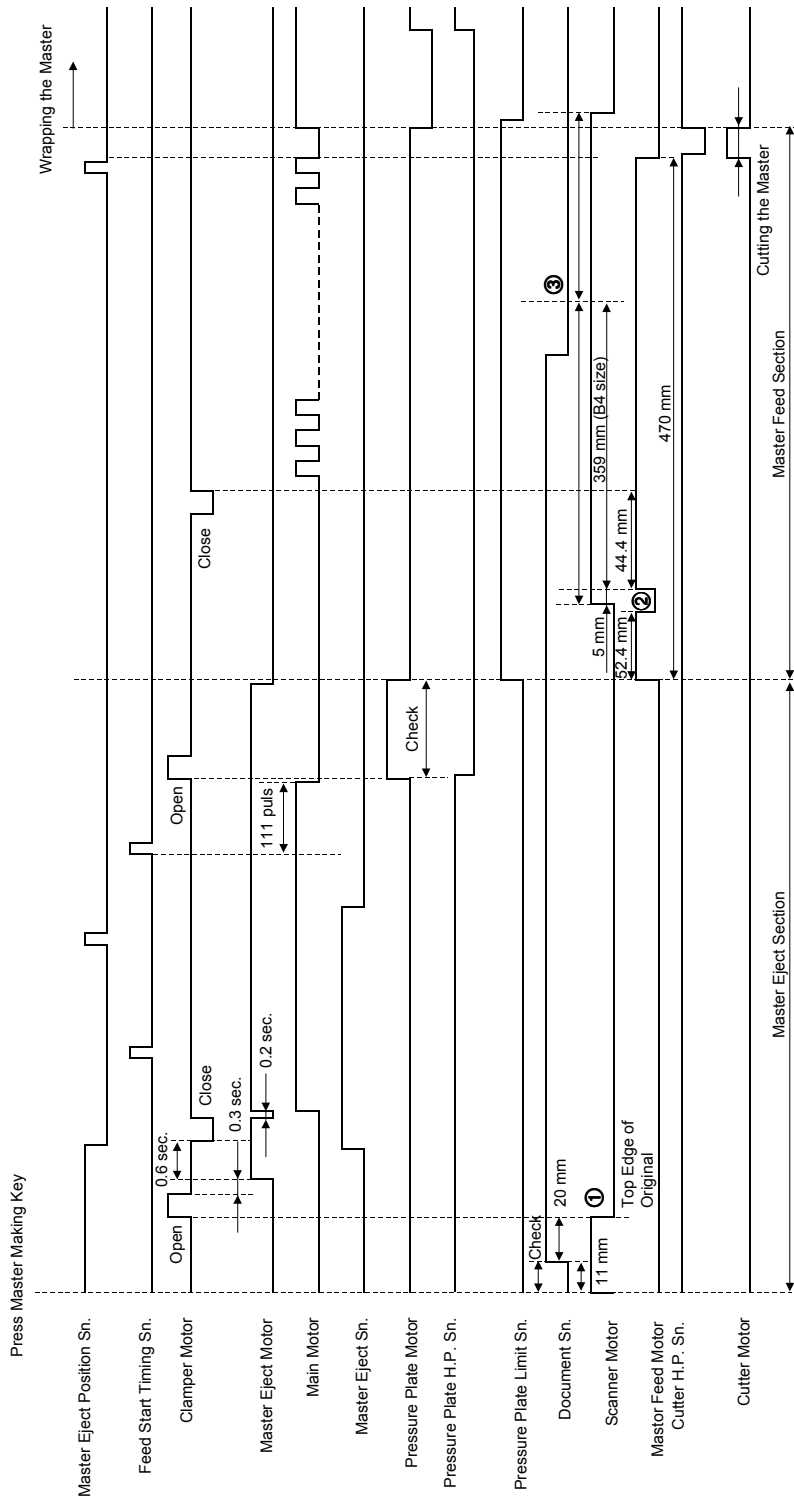

- ① When the scanner motor has fed the original 20 mm since the document sensor turned on, the scanner motor stops.
- ② After scanning 5 mm, the master feed motor turns on.
- ③ After master making, the scanner motor feeds the original out at high speed.

Detailed Descriptions

6.9.2 MASTER WRAPPING

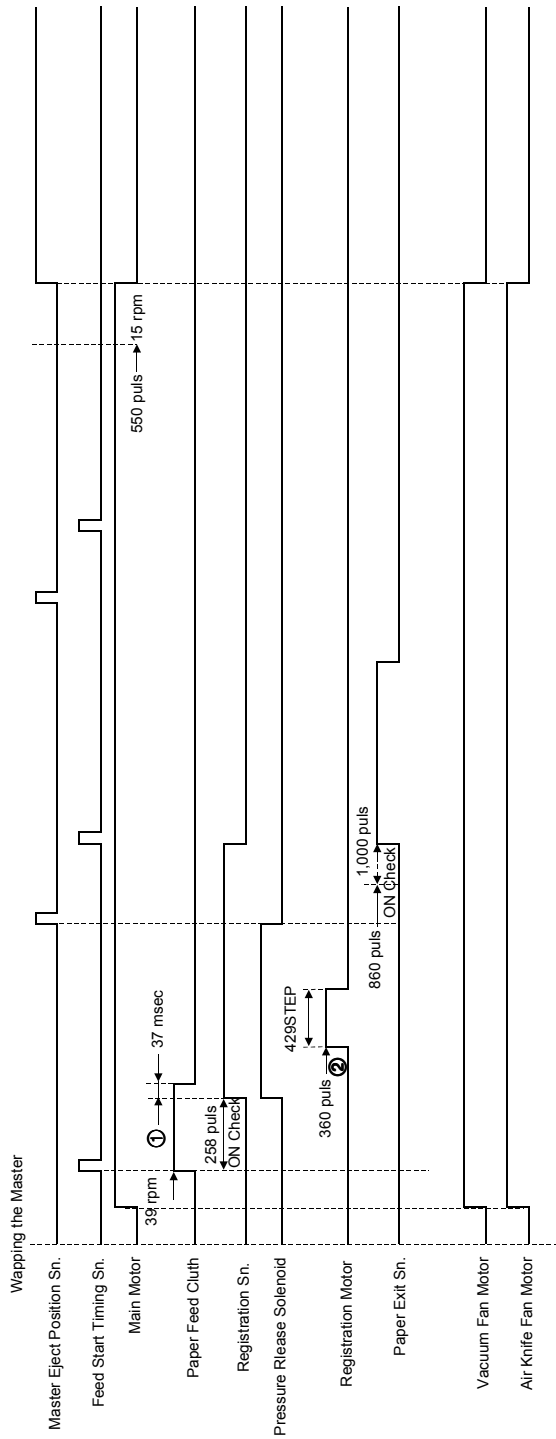

C252D938.WMF

- ① When the drum is at the feed start timing sensor, the paper feed clutch turns on.
- ② When the drum is at the feed start timing sensor position plus 350 pulses, the registration motor turns on for 4298 steps.

6.9.3 PRINTING

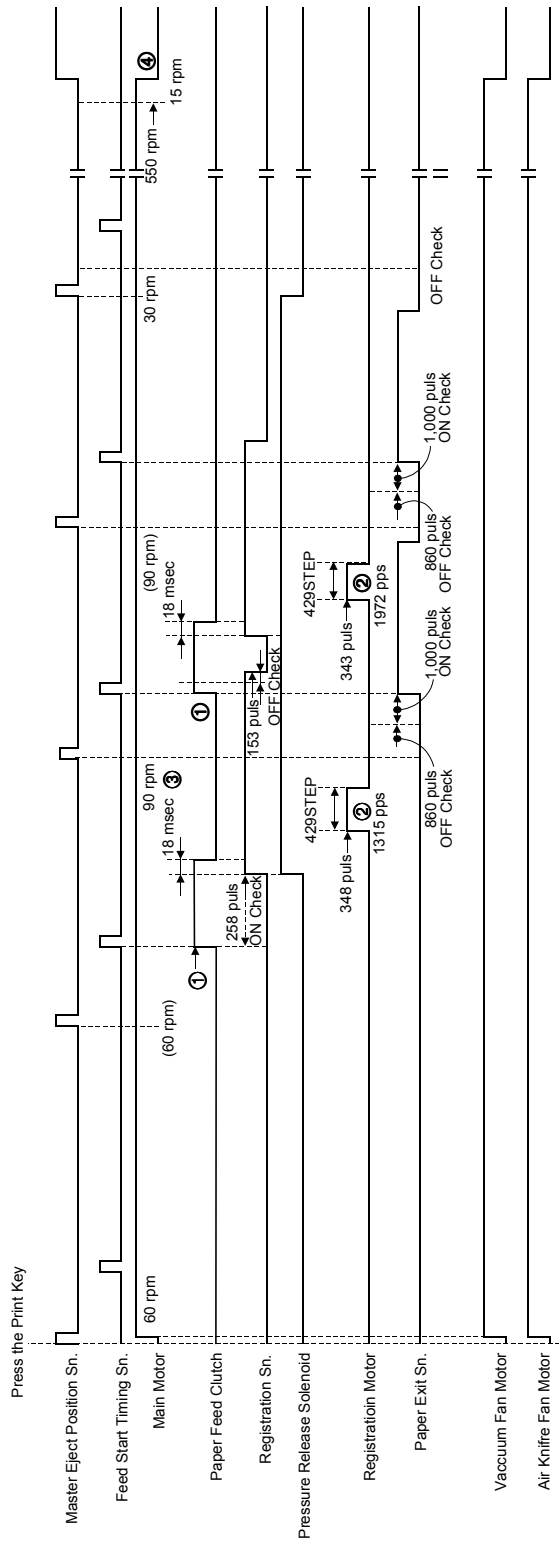

- ① When the drum is at the feed start timing sensor, the paper feed clutch turns on.
- ② When the drum is at the feed start timing sensor position plus 348 pulses, the registration motor turns on for 429 steps.
- ③ When the drum is at the master eject position sensor (drum home position), the drum rotates at the selected printing speed (default: 90 rpm).
- ④ The drum stops at the master eject position sensor (drum home position)







Detailed Descriptions

7. POINT TO POINT DIAGRAM

- Location Map
- Section A
- Section B
- Section C
- Section D
- Section E

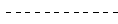
The symbols used in the diagrams are as follows:

- SYMBOL TABLE -

	AC Line
	DC Line
	Pulse Signal Line
	Signal Direction
	Active High Signal
	Active Low Signal

PP2.WMF

Location Map

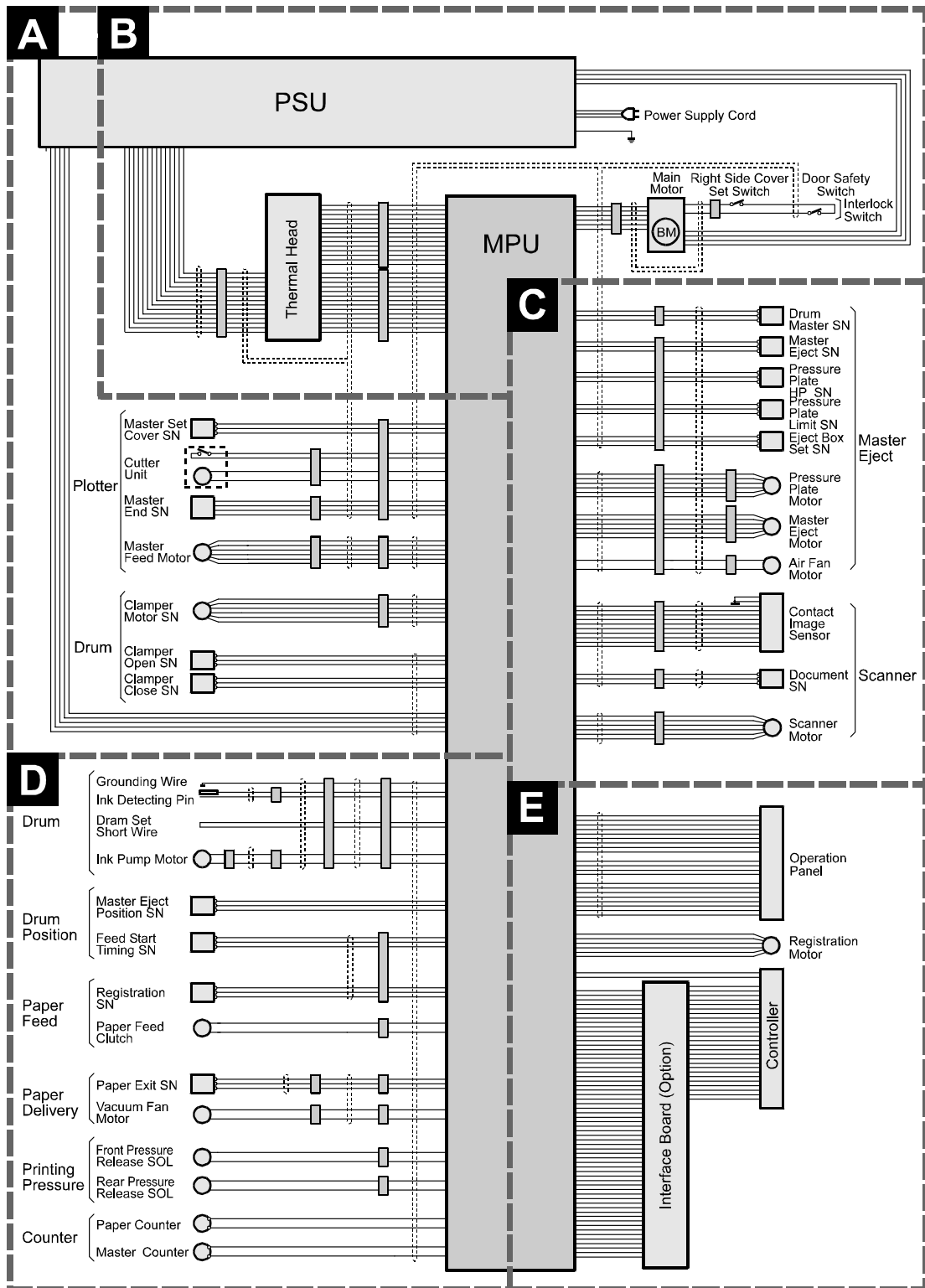

C252S001.WMF

Section A

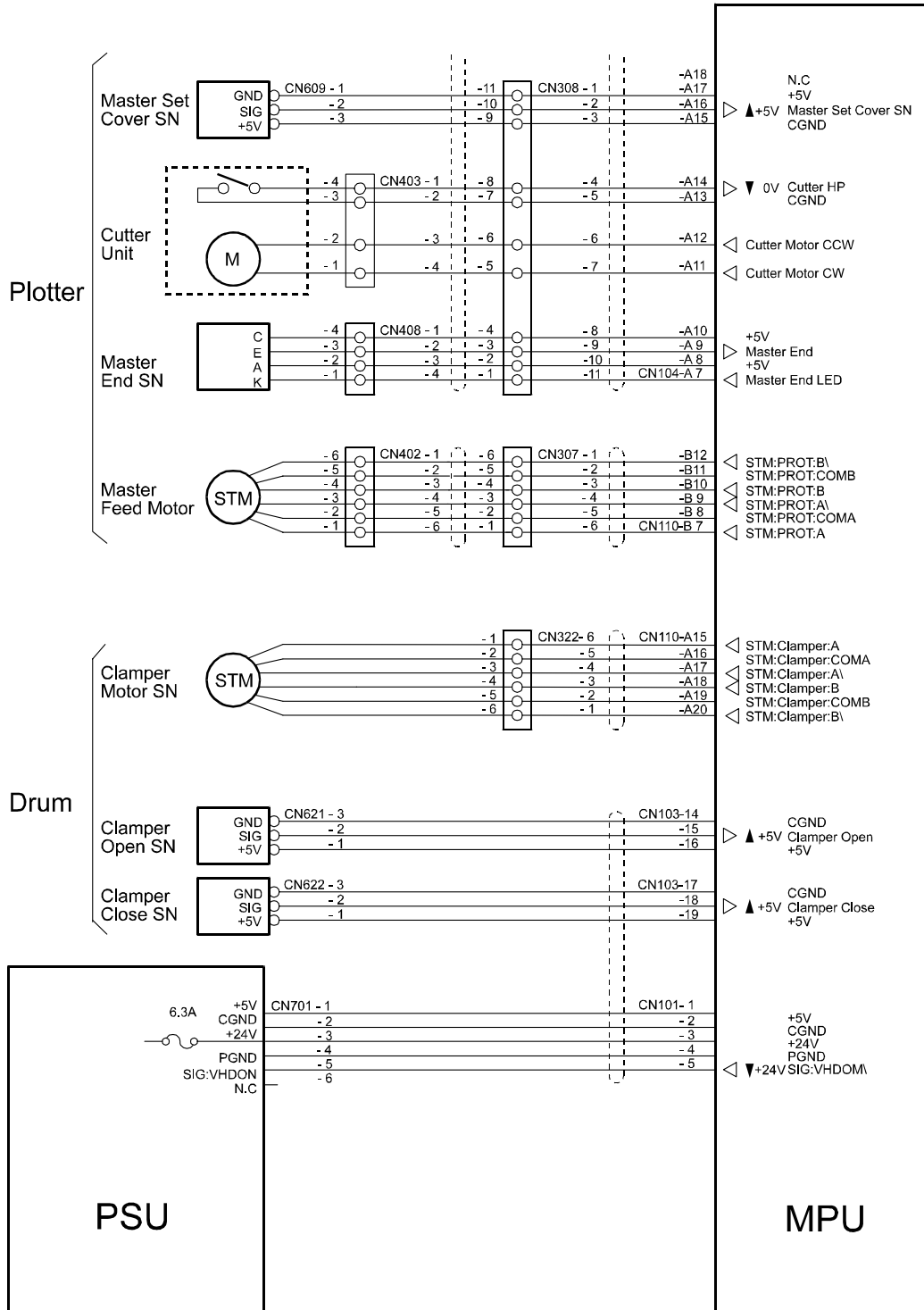

P-to-P

Section B

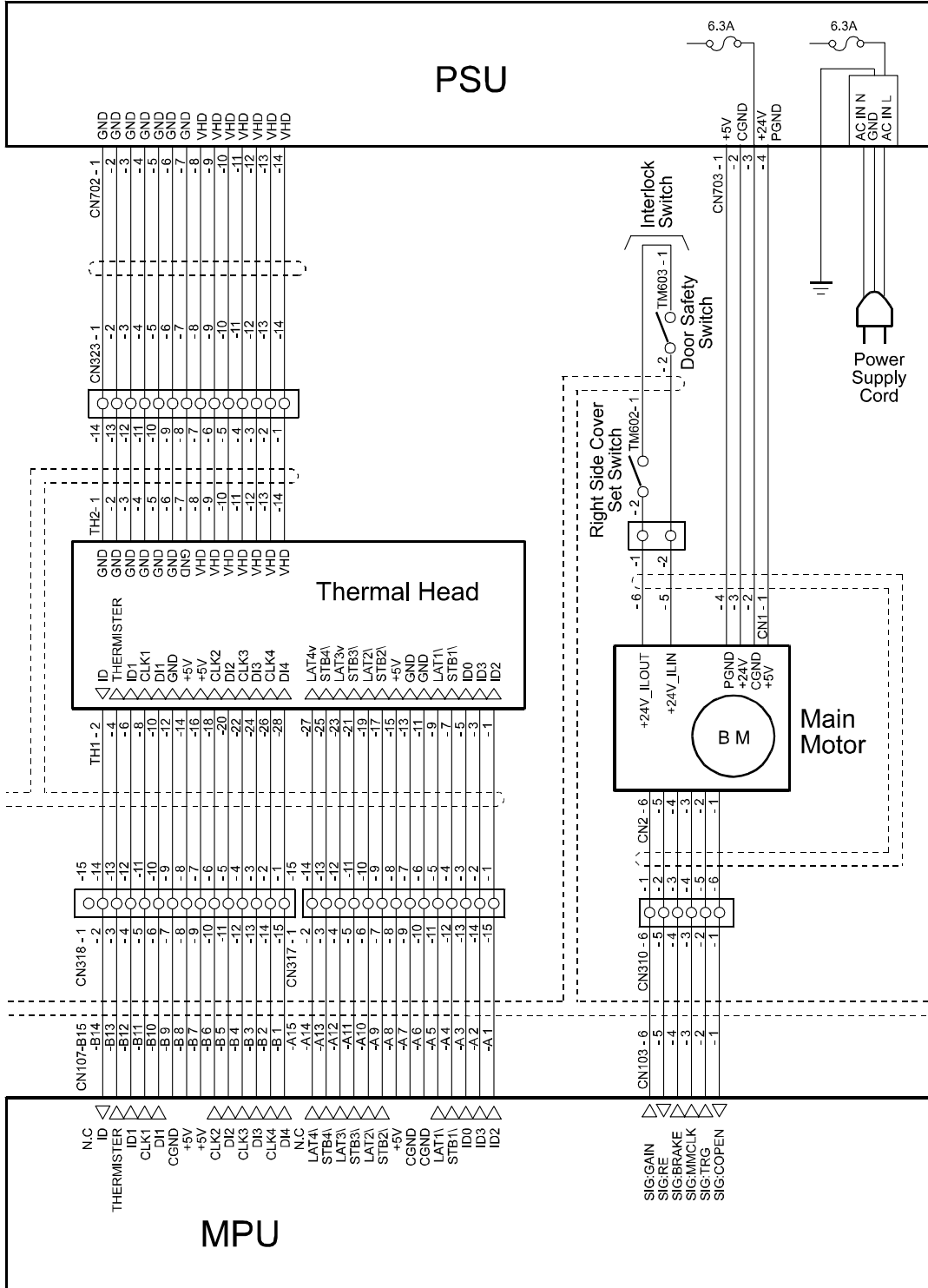

Section C

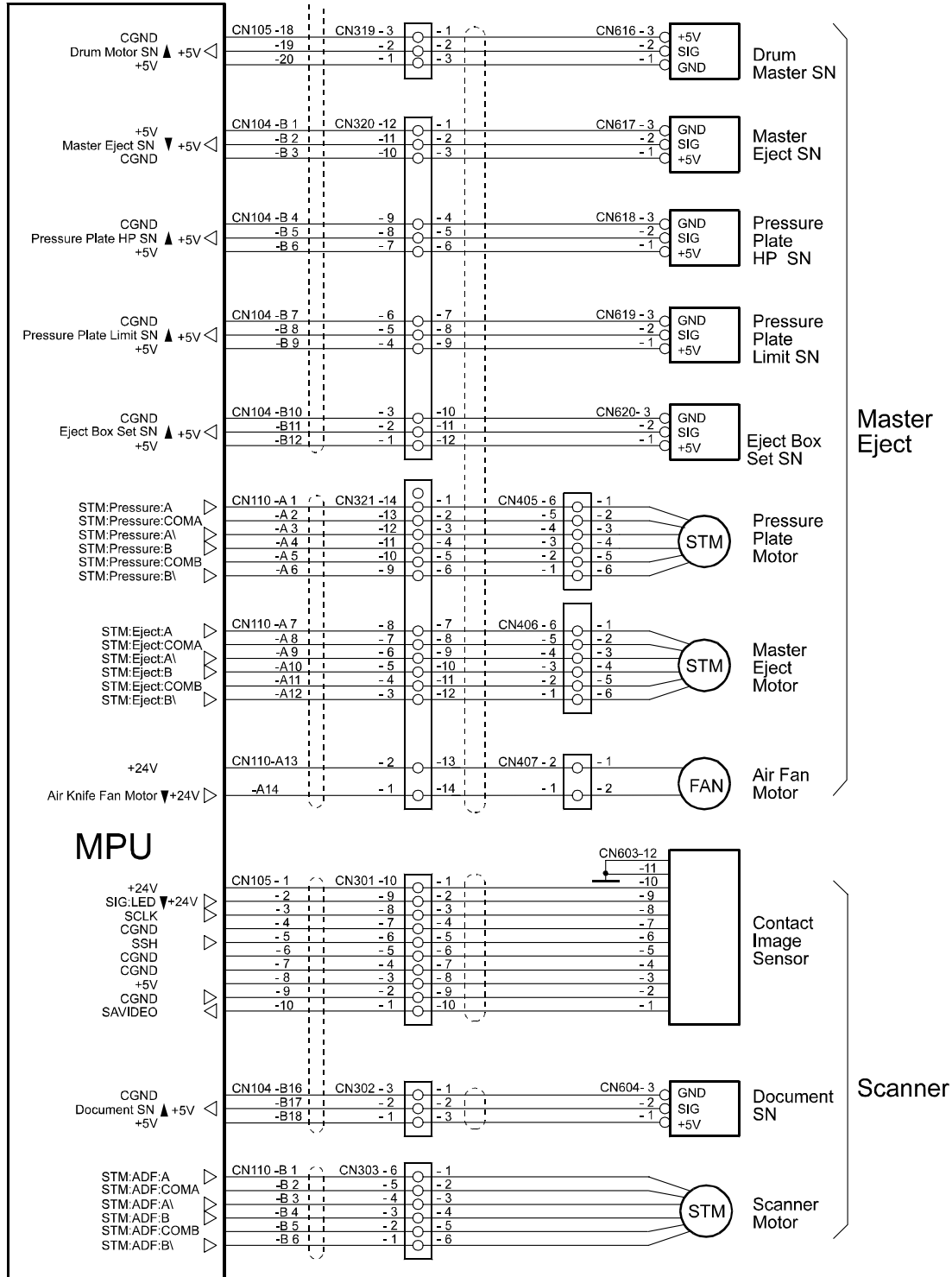

P-to-P

Section D

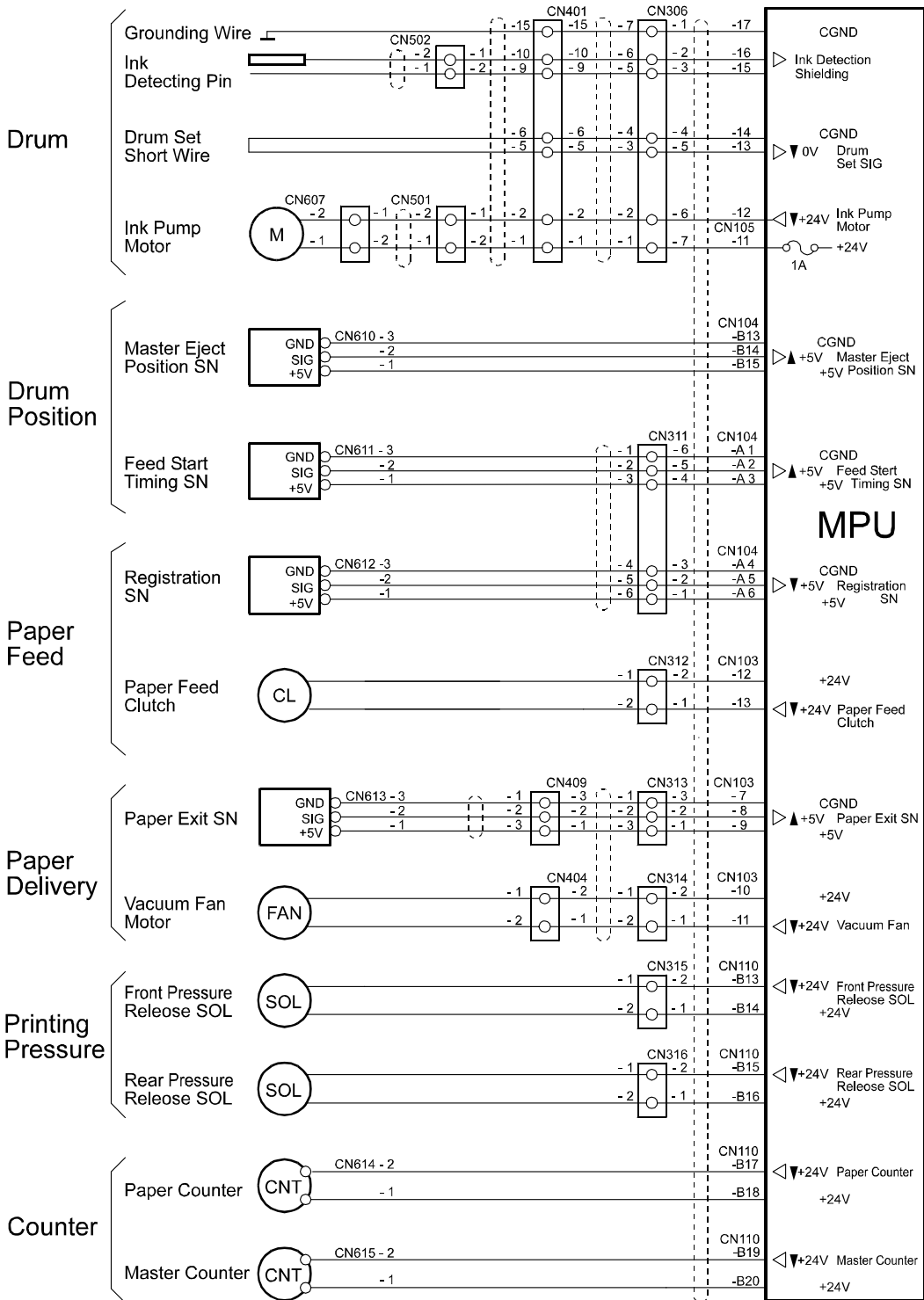

C252S005.WMF

Section E

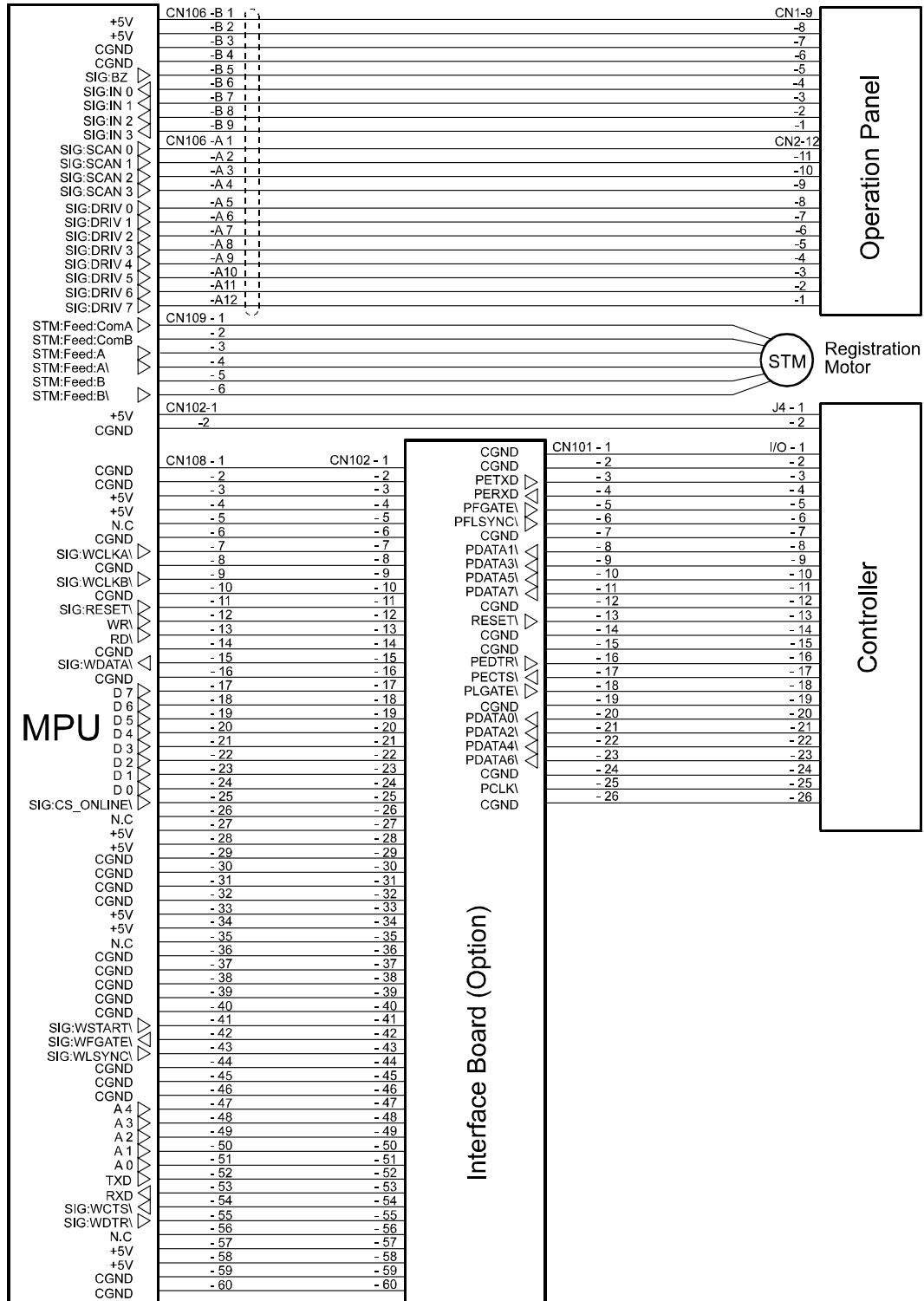

P-to-P

SPECIFICATIONS

1. GENERAL SPECIFICATIONS

Configuration	Desktop
Master Process	Digital with 300 dpi thermal head
Scanning (Pixel Density)	300 dpi
Originals	Sheet
Printing Process	Fully automatic one-drum stencil system
Original Size	Maximum: 275 x 395 mm / 10.8" x 15.6" Minimum: 90 x 140 mm / 3.5" x 5.5"
Original Weight	40.7 – 127.9 g/m ²
Copy Paper Size	Maximum: 275 x 395 mm / 10.8" x 15.6" Minimum: 90 x 140 mm / 3.5" x 5.5"
Copy Paper Weight	35.0 – 127.9 g/m ² (10 to 30 °C) 47.1 – 127.9 g/m ² (More than 30 °C)
Printing Speed	60, 90cpm (2 steps)
Reproduction Ratios	Metric (%): 141, 122, 115, 93, 87, 82, 71 Inch (%): 155, 129, 121, 93, 77, 74, 65
Master Eject Box Capacity	30 masters
Paper Capacity	500 sheets (80 g/m ² , 20lb.)
Paper Delivery Tray Capacity	500 sheets (80 g/m ² , 20lb.)
Power Source	North America: 120 V, 60 Hz, 2.0 A Europe/Asia: 220 - 240 V, 50/60 Hz, 1.1 A
Power Consumption	110 - 120V: Less than 175W, Less than 2.9A 220 - 240V: Less than 175W, less than 1.3A
Noise Emission	Operating Position Sound Power Level: Standby: Not above 22.5 db Copying 60 rpm: Not above 64 db Copying 90 rpm: Not above 68 db Sound Power Level: Standby: Not above 31.2 db Copying 60 rpm: Not above 77 db Copying 90 rpm: Not above 80 db
Dimensions (W x D x H)	Set up: 1332 x 663 x 519 mm (52.5" x 26.1" x 20.5") Stored: 582 x 663 x 519 mm (23.0" x 26.1" x 20.5")
Weight	54 kg (119.1lb.)

Master Processing Time	Less than 45 seconds (A4□, 81/2" x 14□)
First Print Time	Less than 47 seconds (A4□, 81/2" x 14□)
Leading Edge Margin	5 mm ± 3 mm
Side Registration Adjustable Range	± 10 mm
Vertical Registration Adjustable Range	± 10 mm

Master	Master type	280 mm width (B4), 50 m/roll 240 mm width (LG), 50 m/roll
	Yield	100 masters/roll
	Maximum run length per master	2000 prints/master
	Storage conditions	0 to 40 °C, 10 to 95 %RH
	Storage period	One year after production date
Ink	Ink type	500 ml/pack (Black) 600 ml/pack (other colors)
	Available colors	Black, Red, Blue, Green, Brown, Yellow, Violet, Navy, Maroon, Orange, Hunter green
	Storage conditions	-5 to 40 °C, 10 to 95 %RH (Optimum conditions: 15 to 25°C, 20 to 70%RH)
	Storage period	One year after production date (-5 to 40 °C) 18 months after production date (15 to 25 °C)

NOTE: Avoid locations exposed to direct sunlight.